

SS 675 PANEL



UL LISTED CONSTRUCTION NUMBERS

#254 #255 #261 #303
#343 #508 #508A

SECTION ANALYSIS REPORT AND SPAN LOAD TABLES

16265 E 33rd Dr Suite 40, Aurora, CO 80011

PH 303-294-0538 ** 800-574-1717 **** FAX 303-294-9407**

DESCRIPTION**PRODUCT COVERED:**

This section of the Procedure covers a coated steel roof panel which is identified as "Snap Panel 675". The panel is produced at job sites by portable rolling machines.

The panel is roll formed from No. 24 MSG minimum gauge coated steel to the configuration shown in ILL. 1. The panel may also have a paint finish over the coating.

*

SPECIFICATIONS OF FINISHED PRODUCT:**THICKNESS**

The base metal thickness of the steel used in the fabrication of the panel shall be not less than .0225 in. (No. 24 MSG minimum gauge). This thickness shall not include the coating or any paint finish.

DIMENSIONS

The cross-section dimensions of the panel piece shall be in accordance with the cross-section shown in ILL. 1.

STRENGTH

The strength records of the steel shall be reviewed. The steel used shall conform to ASTM A653 Grade 50 specifications or the minimum yield point of the steel shall be 50,000 psi.

DESCRIPTION

PRODUCT COVERED:

This section of the Procedure covers coated steel roof panels which are identified by the manufacturer as "SS675".

The panels are roll-formed from No. 24 MSG minimum gauge coated steel to the configuration shown in ILL. 1. The panels may also have a paint finish over the coating.

SPECIFICATIONS OF FINISHED PRODUCT:

THICKNESS

The base metal thickness of the steel used in the fabrication of the panels shall be not less than 0.0225 in. (No. 24 MSG minimum gauge). This thickness shall not include the coating or any paint finish.

DIMENSIONS

The cross sectional dimensions of the finished panels shall be in accordance with the cross section shown in ILL. 1.

The panels are made in any convenient length.

STRENGTH

The strength records of the manufacturer of the steel shall be reviewed. The steel shall conform to ASTM A653 Grade 50 specifications or the minimum yield point shall be 50,000 psi.

The strength records of the aluminum shall be reviewed. The aluminum shall conform to the Aluminum Association Standard Alloy identified as 3105-H14 with a minimum yield strength of 18,000 psi.



Underwriters Laboratories Inc.

533 Pfingsten Road
Northbrook, Illinois 60062-2096
(847) 272-8800
FAX No. (847) 272-8129
MCI Mail No. 254-3343
Telex No. 6502543343



File R14692
Project 97NK2305

November 14, 1997

CLASSIFICATION BY REPORT

of

METAL ROOF DECK PANEL AND ROOF DECK FASTENERS
IN ROOF DECK CONSTRUCTIONS

New Tech Machinery Corp.
Denver, CO

Copyright © 1997 Underwriters Laboratories Inc.

Underwriters Laboratories Inc. authorizes the above named company to reproduce this Report provided it is reproduced in its entirety.

JH:tim
NKDLS

- Non-Profit Organization
Dedicated to Public Safety and
Committed to Quality Service

G E N E R A L

The subject of this Report is a Roof Deck Panel which is identified as "Snap Panel 675". The panel is used in Construction Nos. 254, 255, 261 and 303 as described in UL's Roofing Materials and Systems Directory. In addition to the roof deck panels, all constructions utilized steel purlins, Classified panel clips and screw fasteners.

The panel in this Report was previously Classified for New Tech Machinery Corp. by Underwriters Laboratories Inc. for Construction Nos. 254, 255 and 261. Since the same panel was tested for these constructions as Construction No. 303, this construction will be included. The panel was identified previously as "675 Panel". The panel in this Report is the same as previously Classified.

The roof deck panel is roll-formed at the construction site. Therefore, the information provided in this Report replaces the Laboratories' usual factory Follow-Up Service Program for metal roof deck panels for which Follow-Up Service is normally conducted at the point of manufacture. The program for companies that are "Classified by Report" consists of keeping supplies of up-to-date Reports that are to be distributed to any interested party and requiring the roll forming machines to be covered by the Underwriters Laboratories Inc. Certificate Service.

The roof deck panel clips are covered by the usual Follow-Up Service Program of Underwriters Laboratories Inc. with factory monitored quality control. The method of use and a description of the Classified panel clips are shown in the Roof Deck Constructions.

D E S C R I P T I O N

Metal Roof Deck Panels - The roof deck panel is a maximum of 18 in. wide and 1-3/4 in. high at the female rib. The panel is fabricated from coated steel having a minimum thickness of 0.0225 in. (No. 24 MSG) and a minimum yield strength of 50,000 psi (ASTM A653, Grade 50). The panel will be Classified as "Metal Roof Deck Panels" in Underwriters Laboratories Inc.'s Roofing Materials and Systems Directory and will be covered under our Follow-Up Service. The panel is designated as "Snap Panel 675" by the manufacturer and is shown in ILL. 1.

C O N C L U S I O N

The following conclusions represent the judgement of Underwriters Laboratories Inc., based upon the results of the examination presented in this Report as they relate to established principles and previously recorded data.

UPLIFT RESISTANCE:

The roof deck assemblies constructed of the materials and in the manner described in Roof Deck Construction Nos. 254, 255, 261 and 303 will afford a Class 90 uplift resistance rating based on the method of test.

Secondary supports (beams, purlins, joists, bulb tees, lateral bracing, etc.), connections of these assemblies to the main structural members (girders, columns, etc.), and construction details along the edges of the roof or around roof openings (mechanical equipment, chimneys, etc.) have not been evaluated.

PRACTICABILITY:

The materials used in the assemblies can be readily installed by qualified workmen with tools and methods commonly used for construction work of a similar nature.

The materials and installation procedures for the original test assemblies described in these tests were judged to be significant factors in the uplift resistance of the constructions.

CONFORMITY:

The original assemblies were tested in accordance with the Standard UL 580, entitled "Tests For Uplift Resistance Of Roof Assemblies."

DESCRIPTION

PRODUCT COVERED:

This section of the Procedure covers coated steel roof panels which are identified by the manufacturer as "SS675".

The panels are roll-formed from No. 24 MSG minimum gauge coated steel to the configuration shown in ILL. 1. The panels may also have a paint finish over the coating.

SPECIFICATIONS OF FINISHED PRODUCT:

THICKNESS

The base metal thickness of the steel used in the fabrication of the panels shall be not less than 0.0225 in. (No. 24 MSG minimum gauge). This thickness shall not include the coating or any paint finish.

DIMENSIONS

The cross sectional dimensions of the finished panels shall be in accordance with the cross section shown in ILL. 1.

The panels are made in any convenient length.

STRENGTH

The strength records of the manufacturer of the steel shall be reviewed. The steel shall conform to ASTM A653 Grade 50 specifications or the minimum yield point shall be 50,000 psi.

CLASSIFICATION INFORMATION:

The following information shall be included on all Classification Markings pertaining to products described in this section:

As To Uplift Resistance Only
Class 90
As Shown By Construction No. 343

MARKING INFORMATION:

In addition, the following information shall appear either on the product or package or on the Classification Marking:

Classified Company's name
Product identification (type designation)
and
Factory identification (if applicable).

CLASSIFICATION AND FOLLOW-UP SERVICE:

The roof deck panel, as described herein, is judged to be eligible for Classification and Follow-Up Service of Underwriters Laboratories Inc. Under the Service, the manufacturer is authorized to use the Laboratories' Certification of Classification on the forming machine to produce products which comply with the fabrication specifications in this Report, as shown by ILL. 1, and any other applicable requirements of Underwriters Laboratories Inc. Only those products which are produced with a Certified machine are considered as Classified by Underwriters Laboratories Inc.

In addition, UL Classification Report Reference No. R14692, Project 97NK2305, dated November 14, 1997, should be consulted for compliance with material specifications and metal panel design.

See UL Roofing Materials and Systems Directory

Report by:

Reviewed by:

James Hatcher
(tjm)

JAMES HATCHER
Staff Engineer

Kenneth Rhodes
(tjm)

KENNETH RHODES
Associate Managing Engineer



NEW TECH MACHINERY CORP
MR G BATTISTELL
1300 40TH ST
DENVER CO 80205

RE: Project Number(s) - 03NK22866

Your most recent Certification is shown below. You may also view this information, or a portion of this information (depending on the product category), on UL's Online Certifications Directory at www.ul.com/database. Please review the text and contact the Conformity Assessment Services staff member who handled your project if revisions are required. For instructions on placing an order for this information in a 3 x 5-inch format, you may refer to the enclosed order form for UL Card Service.

**TJPV
Metal Roof Deck Panels**

November 21, 2003

**NEW TECH MACHINERY CORP
1300 40TH ST, DENVER CO 80205**

R14692

- Coated steel panels, field - formed.
- Underwriters Laboratories Inc. Metal Roof Deck Panels, Fabricated, installed and used in the following roof deck constructions with corresponding panel identifications:
- Coated steel panels identified as "Snap Panel 550" for use in Construction No. 373.
- Coated steel panels identified as "Panel 210A" for use in Construction Nos. 90, 176, 180, 238, 238A.
- Coated steel or aluminum panels identified as "Snap Panel 675" for use in Construction Nos 254, 255, 261, 303.
- Coated steel panels identified as "SS675" for use in Construction Nos. 343, 508 and 508A.
- Coated steel panels identified as "SS450" for use in Construction No. 370.
- Coated steel panels identified as "SS150" for use in Construction No. 554.
- Coated steel panels identified as "SS100" for use in Construction No. 575.
- Coated steel panels identified as "FF100" for use in Construction No. 529.

See Roof Deck Construction for description of construction numbers.

LOOK FOR LISTING MARK ON PRODUCT



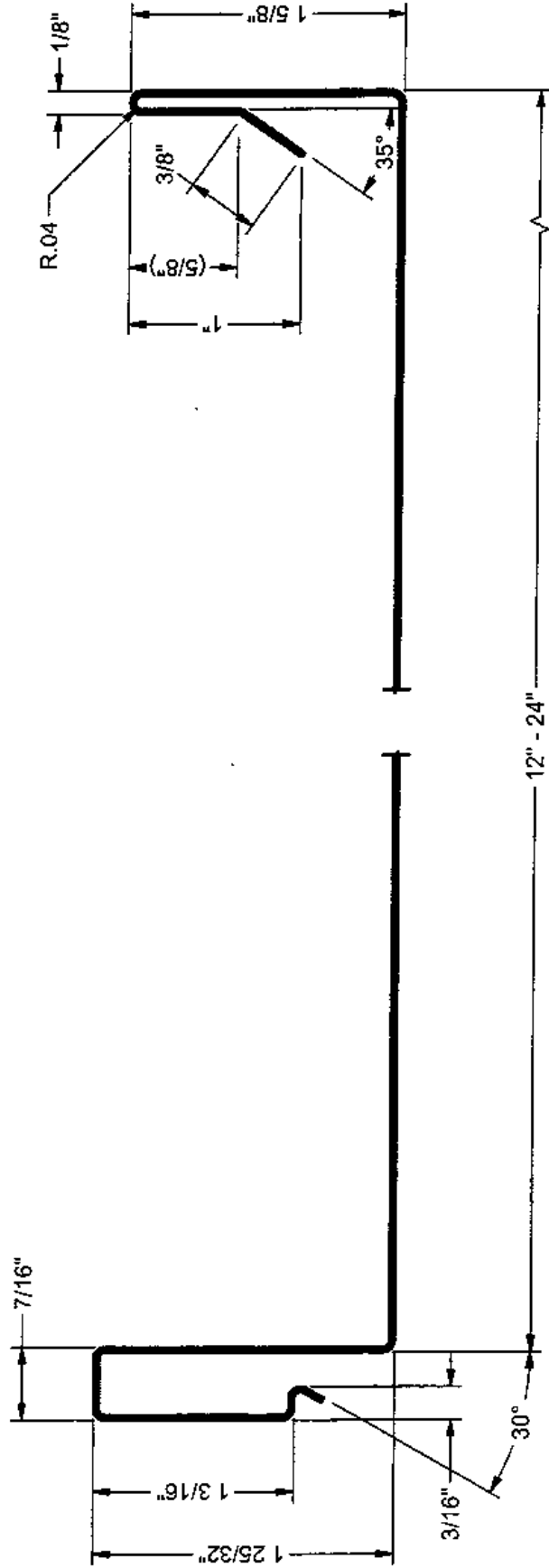
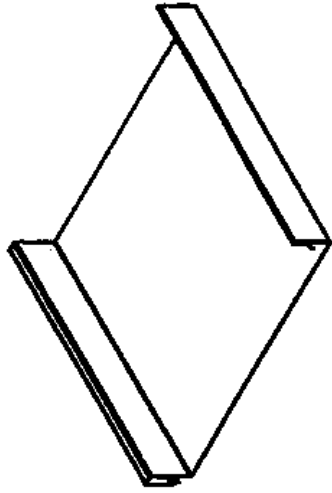

NOTE:
MATERIAL USAGE: 6 1/8"

REV		ECN NO.	DATE	RELEASED BY	TECHNICALS	DRAWN BY	DATE	CHECK BY	DATE	SIZE	SCALE	SHEET	PART NUMBER	REVISION
0			7/2/02		.XX = ± .01 .XXX = ± .005 FRACTION = ± 1/32" ANGLE = ± 1/2'	SAWYER	7/2/2002			A	NONE	1 OF 1	SS675	0
NEW TECH MACHINERY CORP.														
SS675 PANEL PROFILE														

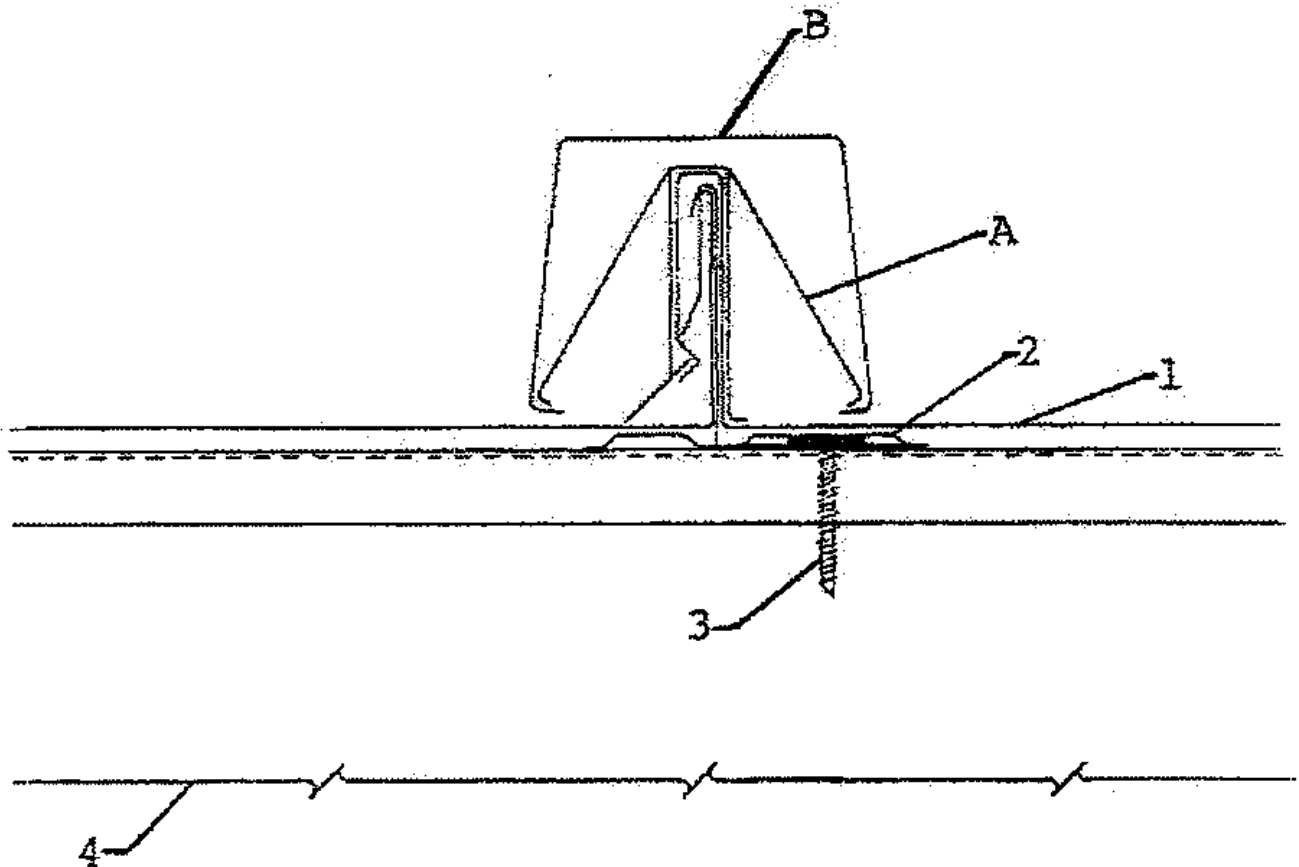

1. Metal Roof Deck Panels * — No. 22 MSG or No. 24 MSG min thickness coated steel panels. Panels 12 in. wide, 1-3/4 in. high at the ribs. Panels continuous over two or more spans. A bead of sealant may be used at panel side joints.

A & S BUILDING SYSTEMS L P — "LokSeam"

AEP SPAN, DIV OF

ASC PROFILES — "12 in. Snap-Seam"

ARCHITECTURAL BUILDING COMPONENTS INC — "Permaseam Panel-18"

ARS INDUSTRIES INC — "US 175LS"

ATAS INTERNATIONAL INC — "K-Lok Structural Panel"

CONSOLIDATED METALS OF FLORIDA, DIV OF

ALUMINUM SERVICE INC — "CSL-675"

CONSTRUCTION METAL PRODUCTS INC — "CMP Series 2000"

DALEY CONSTRUCTION & METAL ROOFING — "3D Super Snap"

ENGLERT INC — "Series 2000"

HI-TEC ROOFING INC — "MRS 210A"

HPM BUILDING SUPPLY — "Shur-Lock"

MBCI — "Lock-Seam"

MESCO METAL BUILDINGS — "LokSeam"

METAL-FAB MFG LLC — "MetFab Snap-On 675"

METAL PANEL SYSTEMS INC — "MP-175"

METAL ROOF COMPONENTS INC — "Snap Tite 175"

METAL ROOFING SYSTEMS INC — "MRS System 2000"

METAL SALES MFG CORP — "Vertical Seam"

METAL SOLUTIONS INC — "SL-175 Snap Lock Panel"

MORIN CORP — "SWL-12", "SWL-16", "SWL-18"

NCI BUILDING SYSTEMS L P — "LokSeam"

NEW TECH MACHINERY CORP — "Snap Panel 675"

PETERSEN ALUMINUM CORP — "Snap-Clad"

PREMIUM PANELS INC — "SS675"

SOUTHEASTERN METALS MANUFACTURING CO — "Verti-Lok"

STEELOX SYSTEMS L L C — "LS-175"

T T & L SHEET METAL INC — "Earl 300"

VICWEST CORP — "AP-12"

WHIRLWIND STEEL BUILDINGS INC — "Weather Snap-12" or "Weather Snap-16"

2. Roof Deck Fasteners * (Panel Clips) — One piece assembly, 3-1/2 in. wide, 1-7/8 in. high, thickness 0.048 in. One panel clip located at each purlin intersection.

AEP SPAN, DIV OF

ASC PROFILES — "Snap Seam Clip"

ARCHITECTURAL BUILDING COMPONENTS INC — "Permaseam Clip"

ATAS INTERNATIONAL INC — "K-Lok Structural Clip"

LOGAN STAMPINGS INC — "Snap Lock Clip No. 675"

NCI BUILDING SYSTEMS L P — " LokSeam UL 90 Clip"

METAL PANEL SYSTEMS INC — "MP-175 Clip"

METAL SALES MFG CORP — "Vertical Seam Clip"

MORIN CORP — "SWL Clip"

PETERSEN ALUMINUM CORP — "Snap-Clad Clip"

STEELOX SYSTEMS L L C — "LS -175 Clip"**VICWEST CORP — "AP Clip"**

2A. Roof Deck Fasteners (Bearing Plate) — (Not Shown) - No. 16 MSG coated steel, 4 in. by 5 in. with guide holes. Used when Rigid Insulation (Item 5) is used.

STEELOX SYSTEMS L L C — "Architectural Bearing Plate"

3. Panel Fasteners (Screws) — Fasteners used to attach panel clips (Item 2) to purlins (Item 4) when no rigid insulation (Item 5) is used to be No. 10-16 by 1 in. long, self-drilling, self-tapping, pancake head, No. 3 point, plated steel screws. When rigid insulation is used, No. 14-13 DPI carbon, pancake head combination Square/Phillips Drive screws to be used. Length to penetrate steel minimum of 5/8 in. Two screws per clip to be used, inserted through panel clip guide holes.

4. Purlins — No. 16 MSG min thickness steel (50,000 psi min yield strength).

Spacing — For 22 MSG thickness panels - 60 in. OC

For 24 MSG thickness panels - 48 in. OC

5. Foamed Plastic (Rigid Insulation) — (Optional) - Not Shown- Maximum thickness 4 in. Located over purlins (Item 4) Density to be minimum 1.8 pcf. Compliant with ASTM C1289 or ASTM C578 Standards, Types IV, X or XII.

The following items may be used in conjunction with the "AEP SPAN" Metal Roof Deck Panels (Item 1). When used, the panel system is identified as "SNAP-SEAM (SBS)".

A. Batten Clips* — Slipped over ribs formed by roof deck panels. One piece assembly, 1-3/4 in. high, 1-3/4 in. max width, with four legs and two arms. Formed to engage ribs of AEP SPAN Panels and Batten Cap (Item B). Clips spaced 48 in. OC.

AEP SPAN, DIV OF**ASC PROFILES — "SNAP-SEAM (SBS) Clip"**

B. Batten Cap* — Slipped over batten clip. Two inches high 1-1/2 in. wide at top with sides formed to engage batten clip. Snapped over batten clips.

AEP SPAN, DIV OF

ASC PROFILES — "SNAP-SEAM (SBS) Batten"

The following items may be used in conjunction with the "K-Lok Structural Panel" (Item 1).

A. Batten Clips* — Slipped over ribs formed by roof deck panels. One piece assembly formed to engage ribs of "K-Lok Structural Panels" (Item 1) and Batten Cap (Item B). Spaced 48 in. O.C.

BEMO-USA CORP — "K-Lok Structural Batten Clip".

B. Batten Cap* — Slipped over batten clip (Item A) and formed to snap and engage batten clip.

BEMO-USA CORP — "K-Lok Structural Batten".

The following items may be used in conjunction with the "Design-Lok" panel (Item 1).

A. Batten Clips* — Slipped over ribs formed by roof deck panels. One piece assembly formed to engage ribs of "Design-Lok" panels (Item 1) and "Design-Lok Batten Cap" (Item B) spaced 48 in. OC.

METAL SALES MFG CORP — "Vertical Seam Batten Clip"

B. Batten Cap* — Slipped over batten clip (Item A), formed to snap over and engage batten clip.

METAL SALES MFG CORP — "Vertical Seam Batten Cap "

The following items may be used in conjunction with the "Structural Standing Seam" panels (Item 1) and a Classified Batten clip as described in this construction.

A. Snapped-on-Batten* — Slipped over a Classified Batten Clip, formed to snap over and engage batten clip.

Refer to General information, Roof Deck Constructions for items not evaluated.

*Bearing the UL Classification Mark

**UL Listed and Classified
Products****UL Recognized
Components****Products Certified for
Canada**

This page and all contents are Copyright © 2004 by Underwriters Laboratories Inc.®

The appearance of a company's name or product in this database does not in itself assure that products so identified have been manufactured under UL's Follow-Up Service. Only those products bearing the UL Mark should be considered to be Listed and covered under UL's Follow-Up Service. Always look for the Mark on the product.

UL permits the reproduction of the material contained on UL's Website subject to the following conditions: 1. The Guide Information, Designs and/or Listings (files) must be presented in their entirety and in a non-misleading manner, without any manipulation of the data (or drawings). 2. The statement "Reprinted from the Online Certifications Directory with permission from Underwriters Laboratories Inc." must appear adjacent to the extracted material. In addition, the reprinted material must include a copyright notice in the following format: "Copyright © 2004 Underwriters Laboratories Inc.®"



Online Certifications Directory

TGKX.255 Roof Deck Constructions

[Page Bottom](#)

[Questions?](#)

[Previous Page](#)

Roof Deck Constructions

Guide Information

Construction No. 255

March 11, 2004

Uplift — Class 90 and 60 (See Item No. 4)

Fire Not Investigated

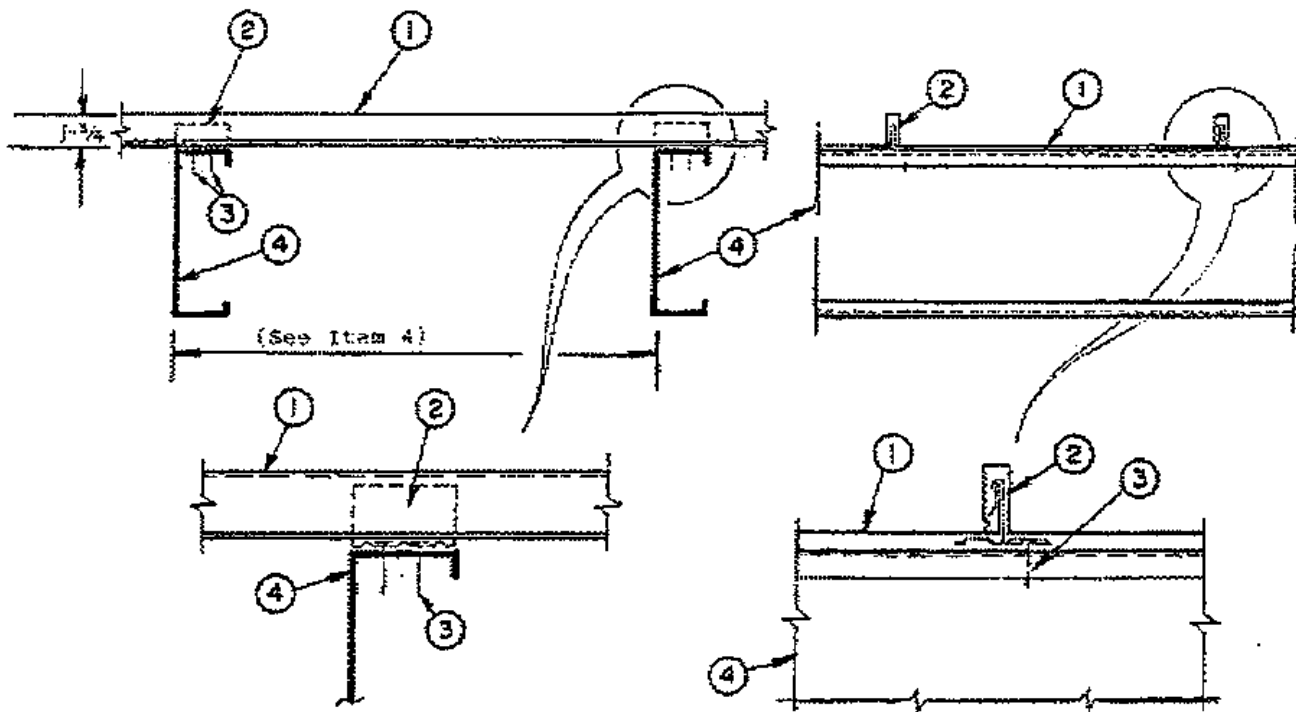

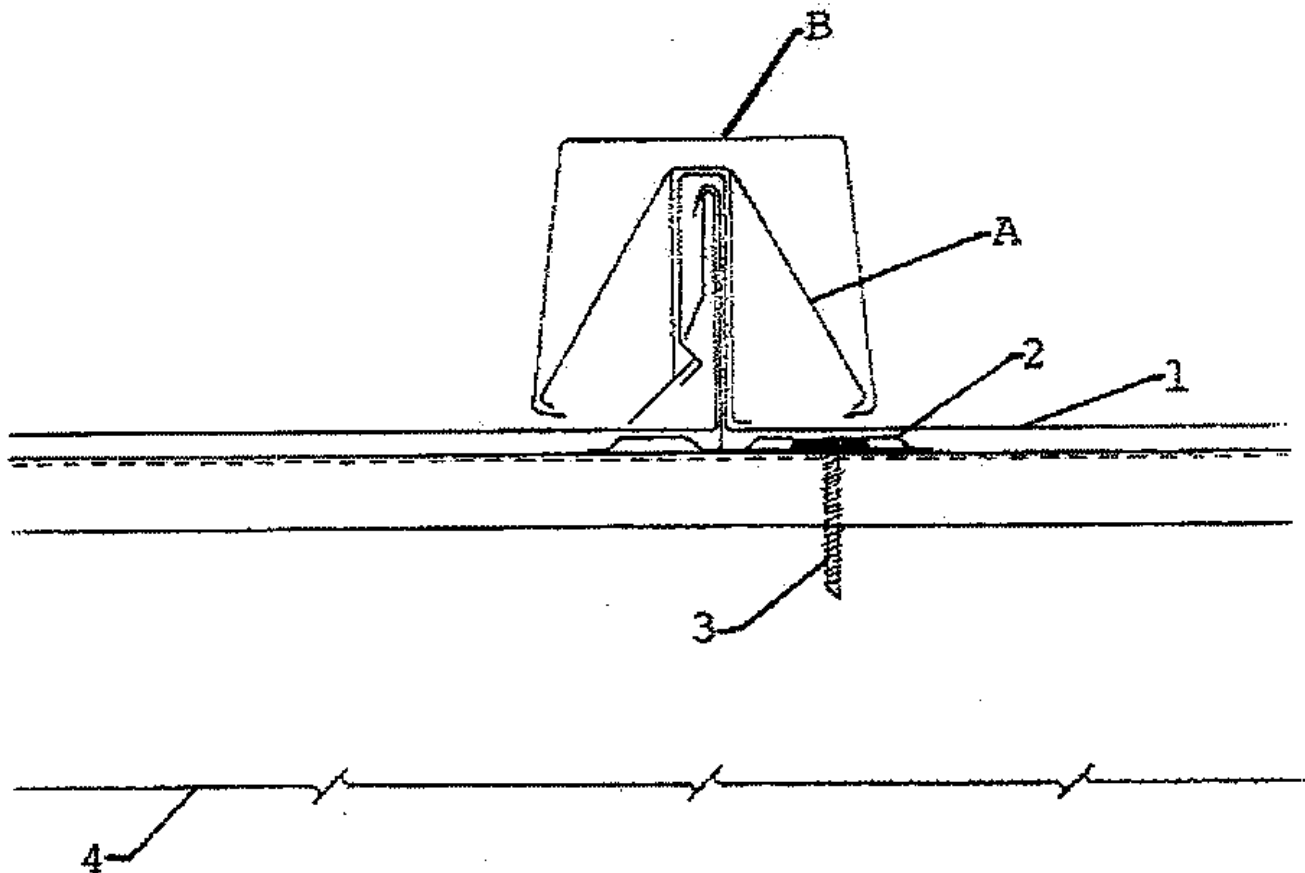

1. **Metal Roof Deck Panels*** — No. 24 MSG min thickness coated steel. Panel width 18 in. max., 10 in. min. Rib height 1-3/4 in. at female side. Panels continuous over two or more spans. A bead of sealant may be used at panel side joints.

A & S BUILDING SYSTEMS LP — "LokSeam"

AEP SPAN, DIV OF

ASC PROFILES — "18 in. Snap Seam"

ARCHITECTURAL BUILDING COMPONENTS INC — "Permaseam Panel"

ATAS INTERNATIONAL INC — "K-Lok Structural Panel"

CENTRIA — "SDP 175-12, -16, -18"

CENTRAL TEXAS METAL ROLLFORMING INC — "SHURLOC 175"

COASTAL METAL SERVICE — "EZ Loc"

**CONSOLIDATED METALS OF FLORIDA, DIV OF
ALUMINUM SERVICE INC — "CSL-675"**

CONSTRUCTION METAL PRODUCTS INC — "CMP Series 2000"

DALEY CONSTRUCTION & METAL ROOFING — "3D Super Snap"

ENGLERT INC — "Series 2000"

HI-TEC ROOFING INC — "MRS 210A"

MCELROY METAL MILL INC — "Medallion-Lok" or "Metalogic-2000"

MBCI — " LokSeam "

MESCO METAL BUILDINGS — "LokSeam"

METAL-FAB MFG LLC — "MetFab Snap-On 675"

METAL ROOF COMPONENTS INC — "Snap Tite 175"

METAL ROOFING SYSTEMS INC — "MRS System 2000"

METAL SALES MFG CORP — "Vertical Seam"

METAL SOLUTIONS INC — "SL-175 Snap Lock Panel"

METAL PANEL SYSTEMS INC — "MP-175"

MORIN CORP — "SWL-12", "SWL-16", "SWL-18"

NCI BUILDING SYSTEMS L P — "LokSeam"

NEW TECH MACHINERY CORP — "Snap Panel 675"

PETERSEN ALUMINUM CORP — "Snap-Clad"

PREMIUM PANELS INC — "SS675"

ROLLCOM — " 175B-12, 175B-16, 175B-18"

SOUTHEASTERN METALS MANUFACTURING CO — "Verti-Lok"

STEELOX SYSTEMS L L C — "LS-175"

T T & L SHEET METAL INC — "Earl 300"

ULTRA SEAM INC — "US 175LS"

VICWEST CORP — "AP-16" or "AP-18"

WHIRLWIND STEEL BUILDINGS INC — "Weather Snap-12" or "Weather Snap-16"

2. Roof Deck Fasteners* — (Panel Clips) — One piece assembly, 3-1/2 in. wide, 1-7/8 in. high. One panel clip located at each purlin intersection.

AEP SPAN, DIV OF

ASC PROFILES — "Snap Seam Clip"

ARCHITECTURAL BUILDING COMPONENTS INC — "Permaseam Clip"

ARCHITECTURAL METAL SPECIALTIES INC — "178-SLU-18-G" and "178-SLP-18G"

ATAS INTERNATIONAL INC — "K-Lok Structural Clip"

CENTRIA — "C175"

COASTAL METAL SERVICE — "EZ Loc Panel Clip"

LOGAN STAMPINGS INC — "Snap Lock Clip No. 675"

MCELROY METAL MILL INC — "Medallion-Lok Clip"

METAL SALES MFG CORP — "Vertical Seam Clip"

MORIN CORP — "SWL Clip"

NCI BUILDING SYSTEMS L P — "Lock-Seam UL 90 Clip"

PETERSEN ALUMINUM CORP — "Snap-Clad Clip"

STEELOX SYSTEMS L L C — "LS-175 Clip"

VICWEST CORP — "AP Clip"

2A. Roof Deck Fasteners (Bearing Plate) — (Not Shown) - No. 16 MSG coated steel, 4 in. by 5 in. with guide holes. Used when Rigid Insulation (Item 5) is used.

STEELOX SYSTEMS L L C — "Architectural Bearing Plate"

3. Panel Fasteners (Screws) — Fasteners used to attach panel clips (Item 2) to purlins (Item 4) when no rigid insulation (Item 5) is used to be No. 10-16 by 1 in. long, self-drilling, self-tapping, pancake head, No. 3 point, plated steel screws. When rigid insulation is used, No. 14-13 DP1 carbon, pancake head combination Square/Phillips Drive screws to be used. Length to penetrate steel minimum of 5/8 in. Two screws per clip to be used, inserted through panel clip guide holes.

4. Purlins — No. 16 MSG min thickness steel (50,000 psi min yield strength).

Spacing for Class 90 to be 48 in. OC: For Class 60 to be 60 in. OC

5. Foamed Plastic (Rigid Insulation) — (Optional) - Not Shown - Maximum thickness 4 in. Located over purlins (Item 4) Density to be minimum 1.8 pcf. Compliant with ASTM C1289 or ASTM C578 Standards, Types IV, X or XII.

The following items may be used in conjunction with the "AEP SPAN" Metal Roof Deck Panels (Item 1). When used, the panel system is identified as "SNAP-SEAM (SBS)".

A. Batten Clips* — Slipped over ribs formed by roof deck panels. One piece assembly, 1-3/4 in. high, 1-3/4 in. max width, with four legs and two arms. Formed to engage ribs of AEP SPAN Panels and Batten Cap (Item 2B). Clips spaced 48 in. OC.

AEP SPAN, DIV OF

ASC PROFILES — "SNAP-SEAM (SBS) Clip"

B. Batten Cap* — Slipped over batten clip. Two inches high 1-1/2 in. wide at top with sides formed to engage batten clip. Snapped over batten clips.

AEP SPAN, DIV OF

ASC PROFILES — "SNAP-SEAM (SBS) Batten"

The following items may be used in conjunction with the "K-Lok Structural Panel" (Item 1).

A. Batten Clips* — Slipped over ribs formed by roof deck panels. One piece assembly formed to engage ribs of "K-Lok Structural Panels (Item 1) and Batten Cap (Item B). Spaced 48 in. OC.

ATAS INTERNATIONAL INC — "K-Lok Structural Batten Clip"

B. Batten Cap* — Slipped over batten clip (Item A) and formed to snap and engage batten clip.

ATAS INTERNATIONAL INC — "K-Lok Structural Batten"

The following items may be used in conjunction with the "Design-Lok" panel (Item 1).

A. Batten Clips* — Slipped over ribs formed by roof deck panels. One piece assembly formed to engage ribs of "Design-Lok" panels (Item 1) and "Design-Lok Batten Cap" (Item B) spaced 48 in. OC.

METAL SALES MFG CORP — "Vertical Seam Batten Clip"

B. Batten Cap* — Slipped over batten clip (Item A), formed to snap over and engage batten clip.

METAL SALES MFG CORP — "Vertical Seam Batten Cap "

The following items may be used in conjunction with the "SDP 175-12, -16, -18" panels (Item 1).

A. Batten Clips* — Slipped over ribs formed by roof deck panels. One piece assembly formed to engage ribs of "SDP 175-12, -16, -18" panels (Item 1) and "SDP175B" battens (Item B). Spaced 48 in. OC.

CENTRIA — "175B"

ROLLCOM — " 175B"

B. Batten Cap* — Slipped over batten clip (Item A) and formed to snap and engage batten clip.

CENTRIA — "SDP 175B"

ROLLCOM — "SDP 175B"

Refer to General Information Roof Deck Constructions for items not evaluated.

*Bearing the UL Classification Mark

[Page Top](#)

[Notice of Disclaimer](#)

[Questions?](#)

[Previous Page](#)

[UL Listed and Classified Products](#)

[UL Recognized Components](#)

[Products Certified for Canada](#)

This page and all contents are Copyright © 2004 by Underwriters Laboratories Inc.®

The appearance of a company's name or product in this database does not in itself assure that products so identified have been manufactured under UL's Follow-Up Service. Only those products bearing the UL Mark should be considered to be Listed and covered under UL's Follow-Up Service. Always look for the Mark on the product.

UL permits the reproduction of the material contained on UL's Website subject to the following conditions: 1. The Guide Information, Designs and/or Listings (files) must be presented in their entirety and in a non-misleading manner, without any manipulation of the data (or drawings). 2. The statement "Reprinted from the Online Certifications Directory with permission from Underwriters Laboratories Inc." must appear adjacent to the extracted material. In addition, the reprinted material must include a copyright notice in the following format: "Copyright © 2004 Underwriters Laboratories Inc.®"



Online Certifications Directory

TGKX.261 Roof Deck Constructions

[Page Bottom](#)

[Questions?](#)

[Previous Page](#)

Roof Deck Constructions

Guide Information

Construction No. 261

October 16, 2003

Uplift — Class 90 or 60

Fire Not Investigated

(See Item No. 4)

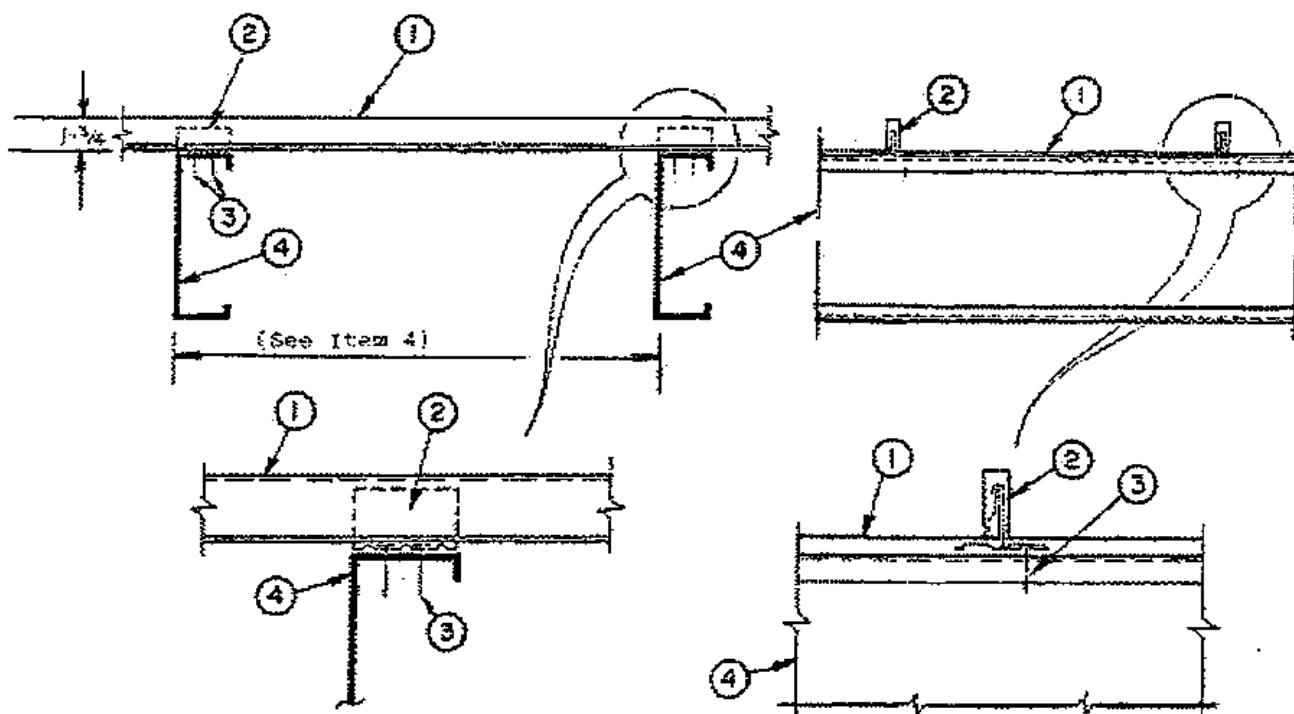

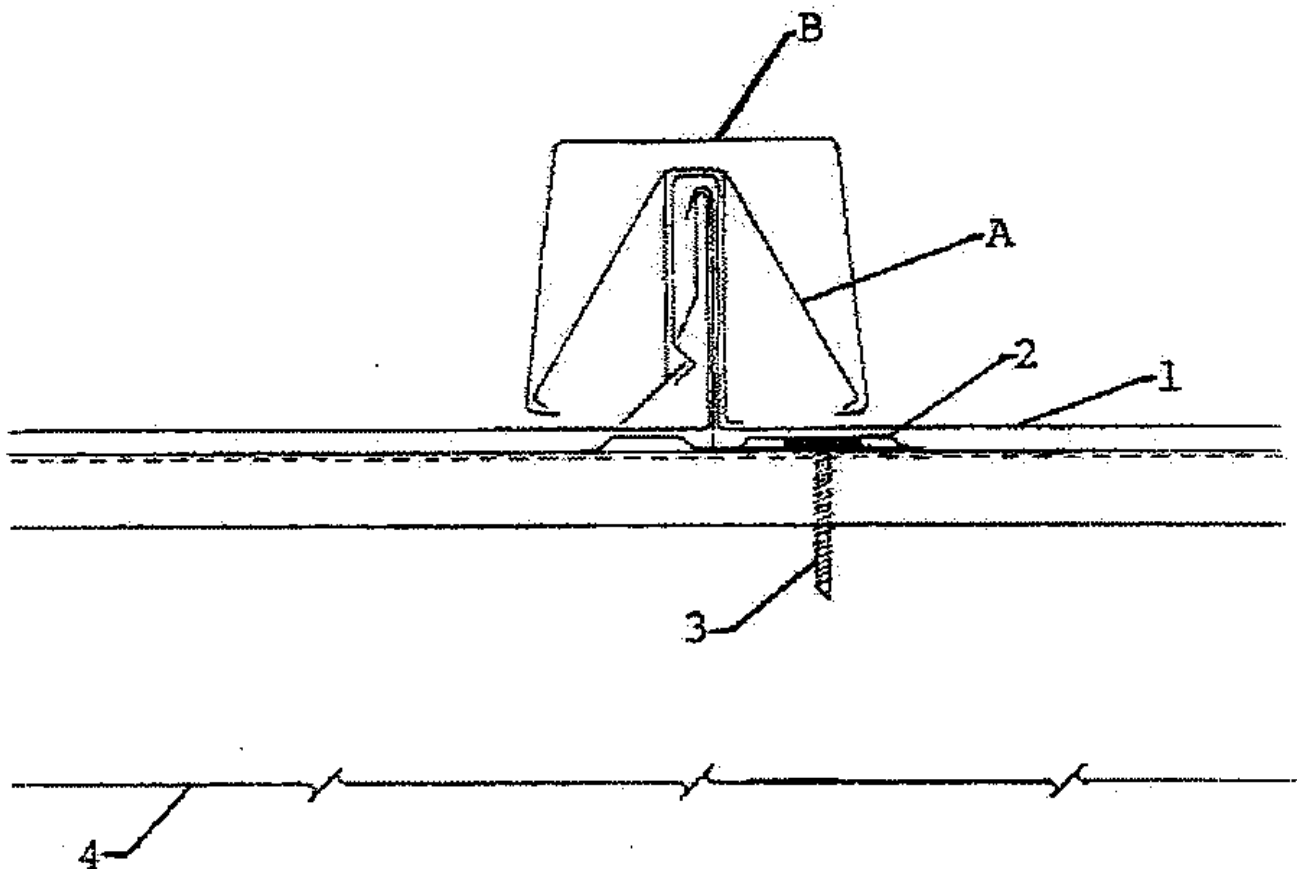

1. **Metal Roof Deck Panels*** — 0.032 in. thick aluminum or No. 24 MSG min thickness coated steel. Panels 10-1/2 in. wide, 1-3/4 in. high at the ribs. Panels continuous over two or more spans. A bead of sealant may be used at panel side joints.

A & S BUILDING SYSTEMS L P — "LokSeam"

AEP SPAN, DIV OF

ASC PROFILES — "10 in. Snap Seam"

ARS INDUSTRIES INC — "US 175LS"

ATAS INTERNATIONAL INC — "K-Lok Structural Panel"

CONSOLIDATED METALS OF FLORIDA, DIV OF

ALUMINUM SERVICE INC — "CSL-675"

CONSTRUCTION METAL PRODUCTS INC — "CMP Series 2000"

DALEY CONSTRUCTION & METAL ROOFING — "3D Super Snap"

ENGLERT INC — "Series 2000"

HI-TEC ROOFING INC — "MRS 210A"

MBCI — "Lock-Seam"

MESCO METAL BUILDINGS — "LokSeam"

METAL-FAB MFG LLC — "MetFab Snap-On 675"

METAL PANEL SYSTEMS INC — "MP-175"

METAL ROOF COMPONENTS INC — "Snap Tite 175"

METAL ROOFING SYSTEMS INC — "MRS System 2000"

METAL SALES MFG CORP — "Vertical Seam"

METAL SOLUTIONS INC — "SL-175 Snap Lock Panel"

MORIN CORP — "SWL-12", "SWL-16", "SWL-18"

NCI BUILDING SYSTEMS L P — "LokSeam"

NEW TECH MACHINERY CORP — "Snap Panel 675"

PREMIUM PANELS INC — "SS675"

PETERSEN ALUMINUM CORP — "Snap-Clad"

SOUTHEASTERN METALS MANUFACTURING CO — "Verti-Lok"

STEELOX SYSTEMS L L C — "LS-175"

T T & L SHEET METAL INC — "Earl 300"

WHIRLWIND STEEL BUILDINGS INC — "Weather Snap-12" or "Weather Snap-16"

2. Roof Deck Fasteners* (Panel Clips) — One piece assembly, 3-1/8 in. wide, 1-7/8 in. high. One panel clip located at each purlin intersection. Min thickness 0.048 in. (No. 18 MSG).

AEP SPAN, DIV OF

ASC PROFILES — "Snap Seam Clip"

ATAS INTERNATIONAL INC — "K-Lok Structural Clip"

LOGAN STAMPINGS INC — "Snap Lock Clip No. 675"

METAL PANEL SYSTEMS INC — "MP-175 Clip"

MORIN CORP — "SWL Clip"

NCI BUILDING SYSTEMS L P — "Lock-Seam UL 90 Clip"

PETERSEN ALUMINUM CORP — "Snap-Clad Clip"

STEELOX SYSTEMS L L C — "LS-175 Clip"

2A. Roof Deck Fasteners (Bearing Plate) — (Not Shown) - No. 16 MSG coated steel, 4 in. by 5 in. with guide holes. Used when Rigid Insulation (Item 5) is used.

STEELOX SYSTEMS L L C — "Architectural Bearing Plate"

3. Panel Fasteners (Screws) — Fasteners used to attach panel clips (Item 2) to purlins (Item 4) when no rigid insulation (Item 5) is used to be No. 10-16 by 1 in. long, self-drilling, self-tapping, pancake head, No. 3 point, plated steel screws. When

rigid insulation is used, No. 14-13 DP1 carbon, pancake head combination Square/Phillips Drive screws to be used. Length to penetrate steel minimum of 5/8 in. Two screws per clip to be used, inserted through panel clip guide holes.

4. **Purlins** — No. 16 MSG min thickness steel (50,000 psi min yield strength). Spacing: For aluminum panels: For Class 90 to be 36 in. OC. For Class 60 to be 48 in. OC. For steel panels: 22 MSG thick to be 60 in. OC. 24 MSG thick to be 48 in. OC.

5. **Foamed Plastic (Rigid Insulation)** — (Optional) - Not Shown - Maximum thickness 4 in. Located over purlins (Item 4) Density to be minimum 1.8 pcf. Compliant with ASTM C1289 or ASTM C578 Standards, Types IV, X or XII.

The following items may be used in conjunction with the "AEP SPAN" Metal Roof Deck Panels (Item 1). When used, the panel system is identified as "SNAP-SEAM (SBS)".

A. **Batten Clips*** — Slipped over ribs formed by roof deck panels. One piece assembly, 1-3/4 in. high, 1-3/4 in. max width, with four legs and two arms. Formed to engage ribs of AEP SPAN Panels and Batten Cap (Item 2B). Clips spaced 48 in. OC.

AEP SPAN, DIV OF

ASC PROFILES — "SNAP-SEAM (SBS) Clip"

B. **Batten Cap*** — Slipped over batten clip. Two inches high 1-1/2 in. wide at top with sides formed to engage batten clip. Snapped over batten clips.

AEP SPAN, DIV OF

ASC PROFILES — "SNAP-SEAM (SBS) Batten"

The following items may be used in conjunction with the "K-Lok Structural Panel" (Item 1).

A. **Batten Clips*** — Slipped over ribs formed by roof deck panels. One piece assembly formed to engage ribs of "K-Lok Structural Panels" (Item 1) and Batten Cap (Item B). Spaced 48 in. OC.

ATAS INTERNATIONAL INC — "K-Lok Structural Batten Clip"

B. **Batten Cap*** — Slipped over batten clip (Item A) and formed to snap and engage batten clip.

ATAS INTERNATIONAL INC — "K-Lok Structural Batten"

The following items may be used in conjunction with the "Design-Lok" panel (Item 1).

A. **Batten Clips*** — Slipped over ribs formed by roof deck panels. One piece assembly formed to engage ribs of "Design-Lok" panels (Item 1) and "Design-Lok Batten Cap" (Item 2) spaced 48 in. OC.

METAL SALES MFG CORP — "Vertical Seam Batten Clip"

B. **Batten Cap*** — Slipped over batten clip (Item A), formed to snap over and engage batten clip.

METAL SALES MFG CORP — "Vertical Seam Batten Cap "

Refer to General information, Roof Deck Constructions for items not evaluated.

*Bearing the UL Classification Mark

[Page Top](#)

[Notice of Disclaimer](#)

[Questions?](#)

[Previous Page](#)

[UL Listed and Classified Products](#)

[UL Recognized Components](#)

[Products Certified for Canada](#)

This page and all contents are Copyright © 2004 by Underwriters Laboratories Inc.®

The appearance of a company's name or product in this database does not in itself assure that products so identified have been manufactured under UL's Follow-Up Service. Only those products bearing the UL Mark should be considered to be Listed and covered under UL's Follow-Up Service. Always look for the Mark on the product.

UL permits the reproduction of the material contained on UL's Website subject to the following conditions: 1. The Guide Information, Designs and/or Listings (files) must be presented in their entirety and in a non-misleading manner, without any manipulation of the data (or drawings). 2. The statement "Reprinted from the Online Certifications Directory with permission from Underwriters Laboratories Inc." must appear adjacent to the extracted material. In addition, the reprinted material must include a copyright notice in the following format: "Copyright © 2004 Underwriters Laboratories Inc.®"



Online Certifications Directory

TGKX.303 Roof Deck Constructions

[Page Bottom](#)

[Questions?](#)

[Previous Page](#)

Roof Deck Constructions

Guide Information

Construction No. 303

March 11, 2004

Uplift — Class 90

Fire Not Investigated (except when 4B is used)

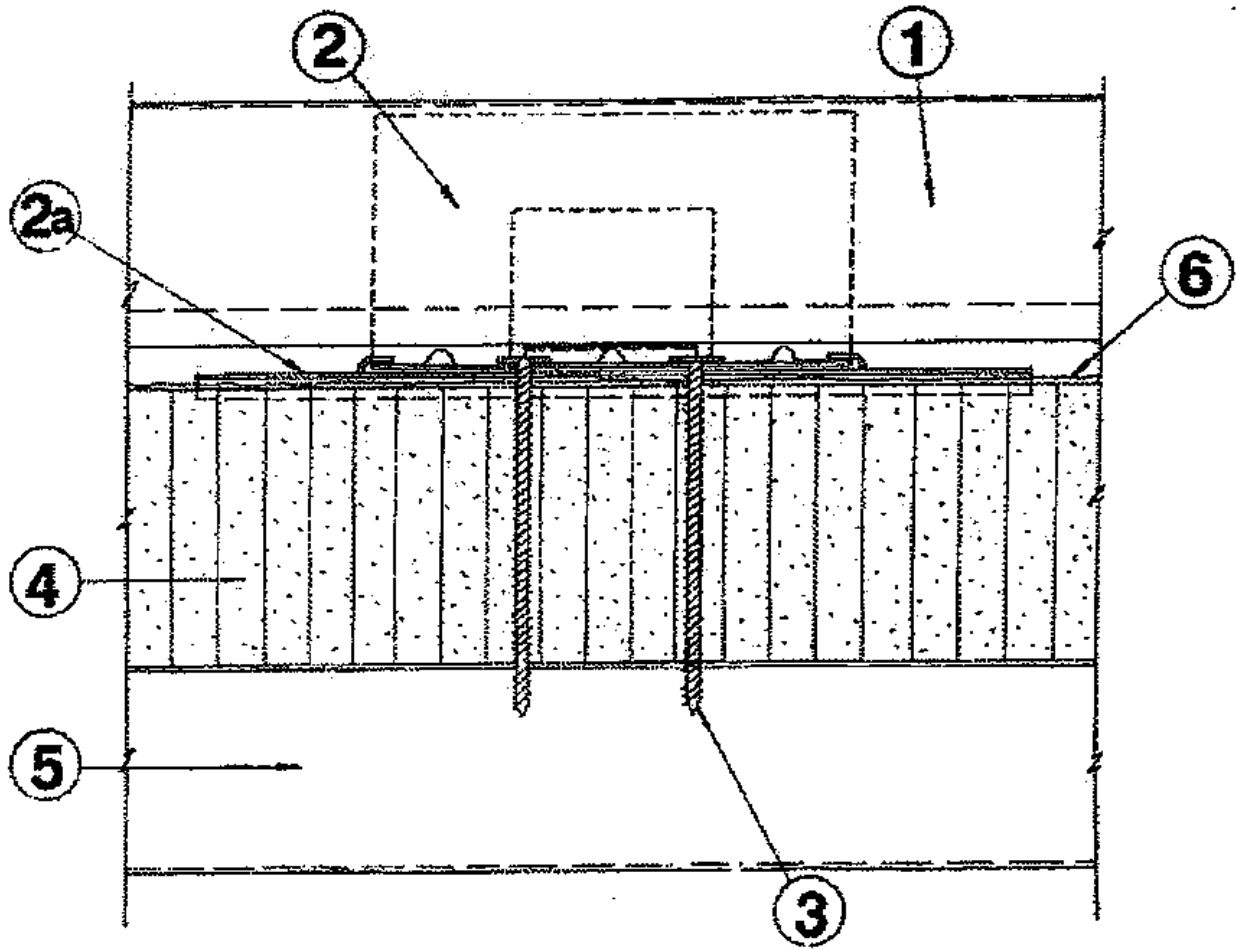

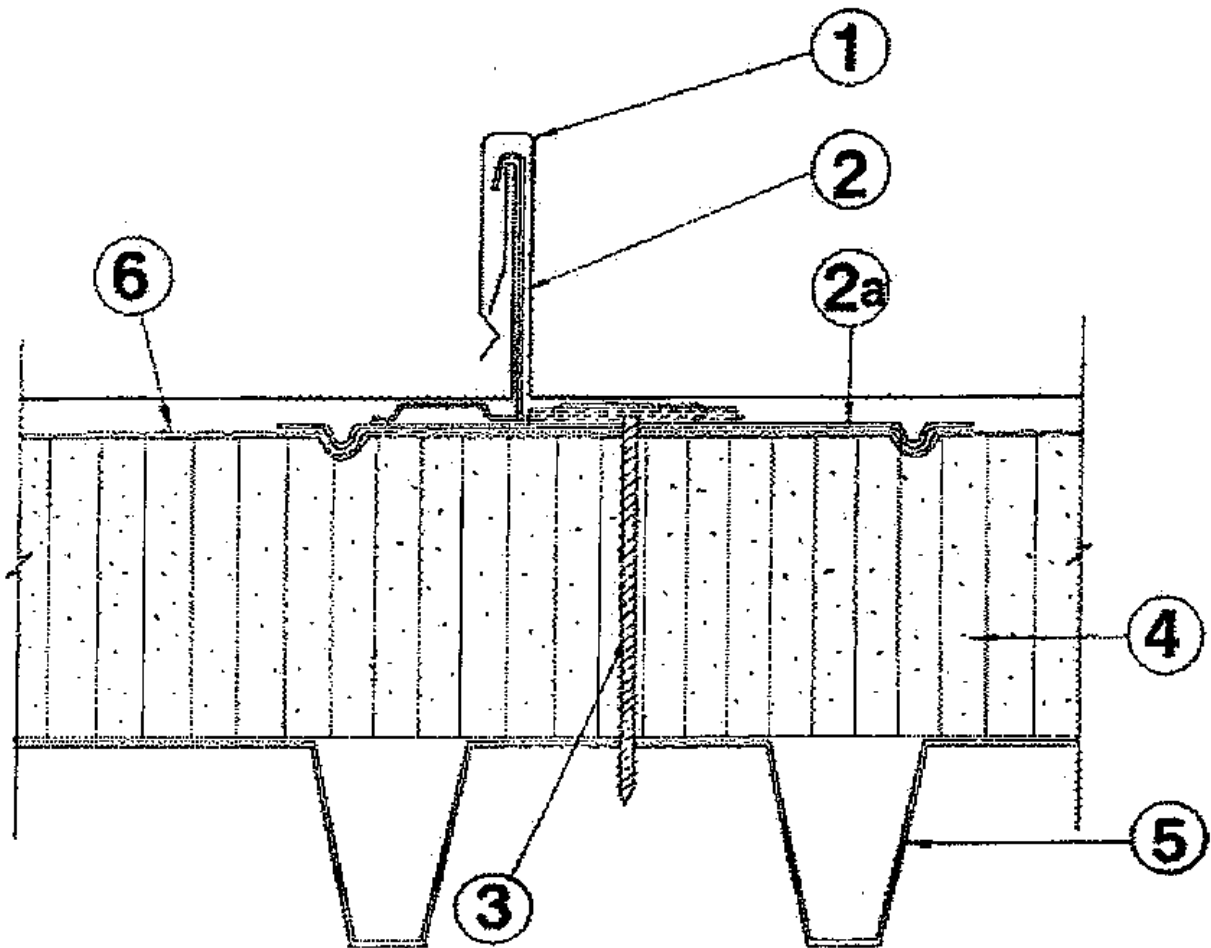

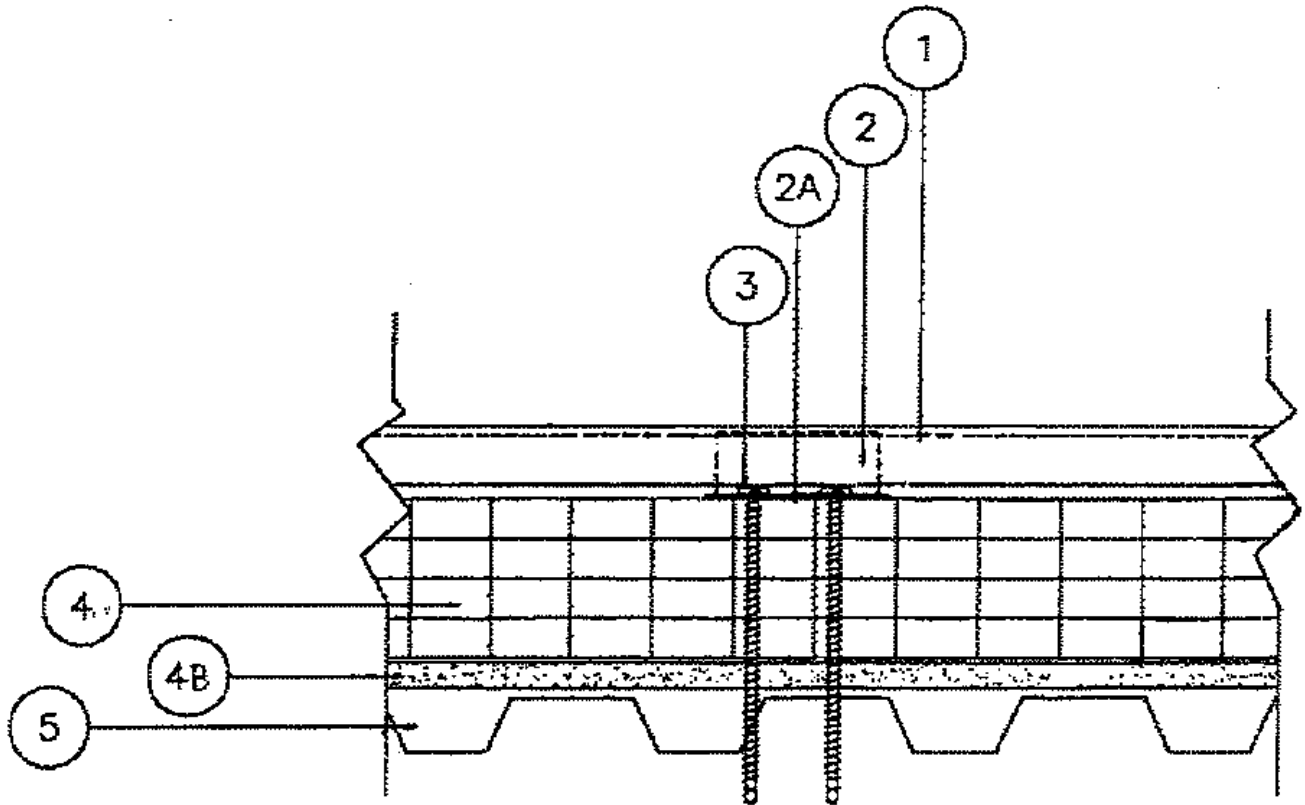
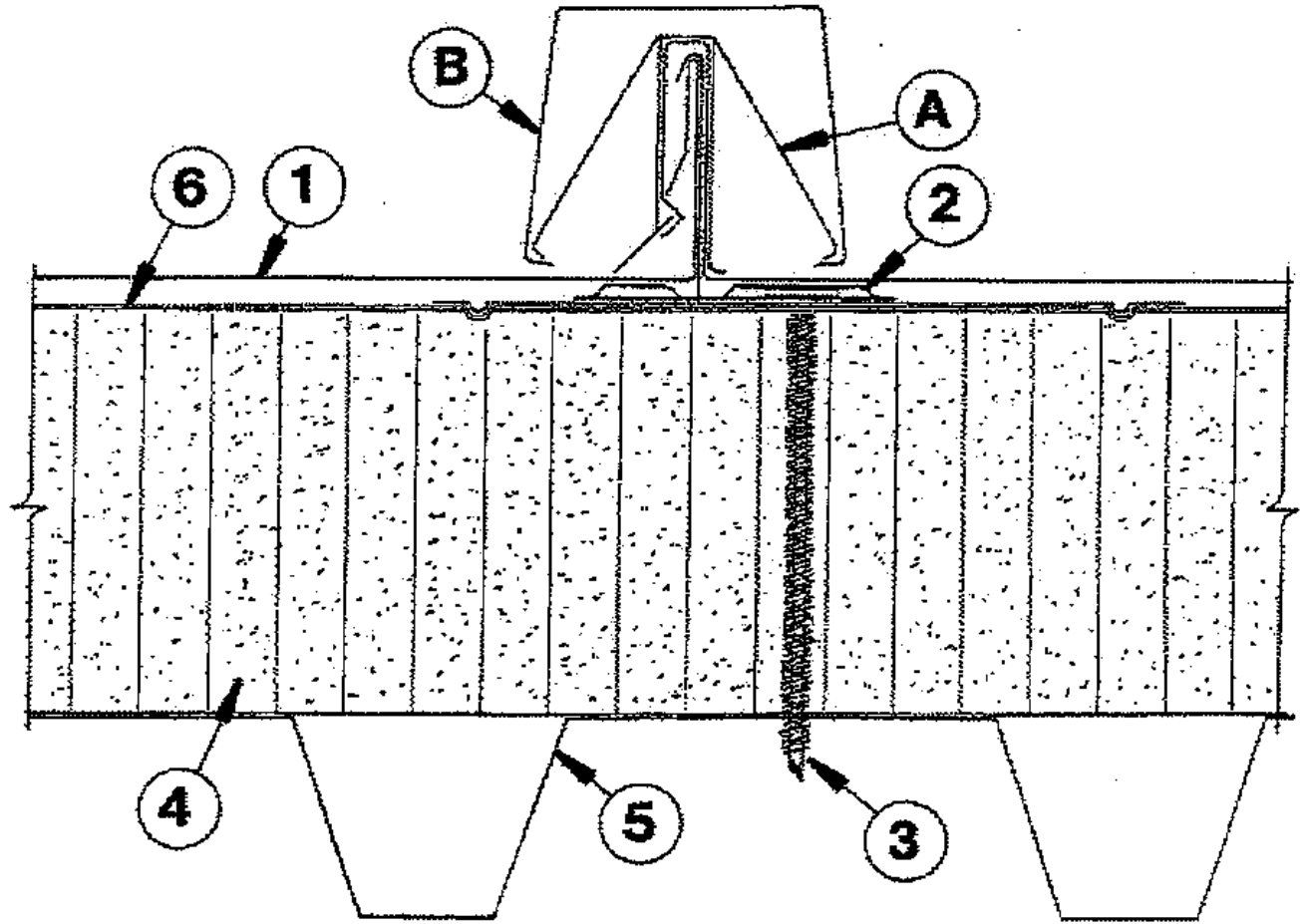

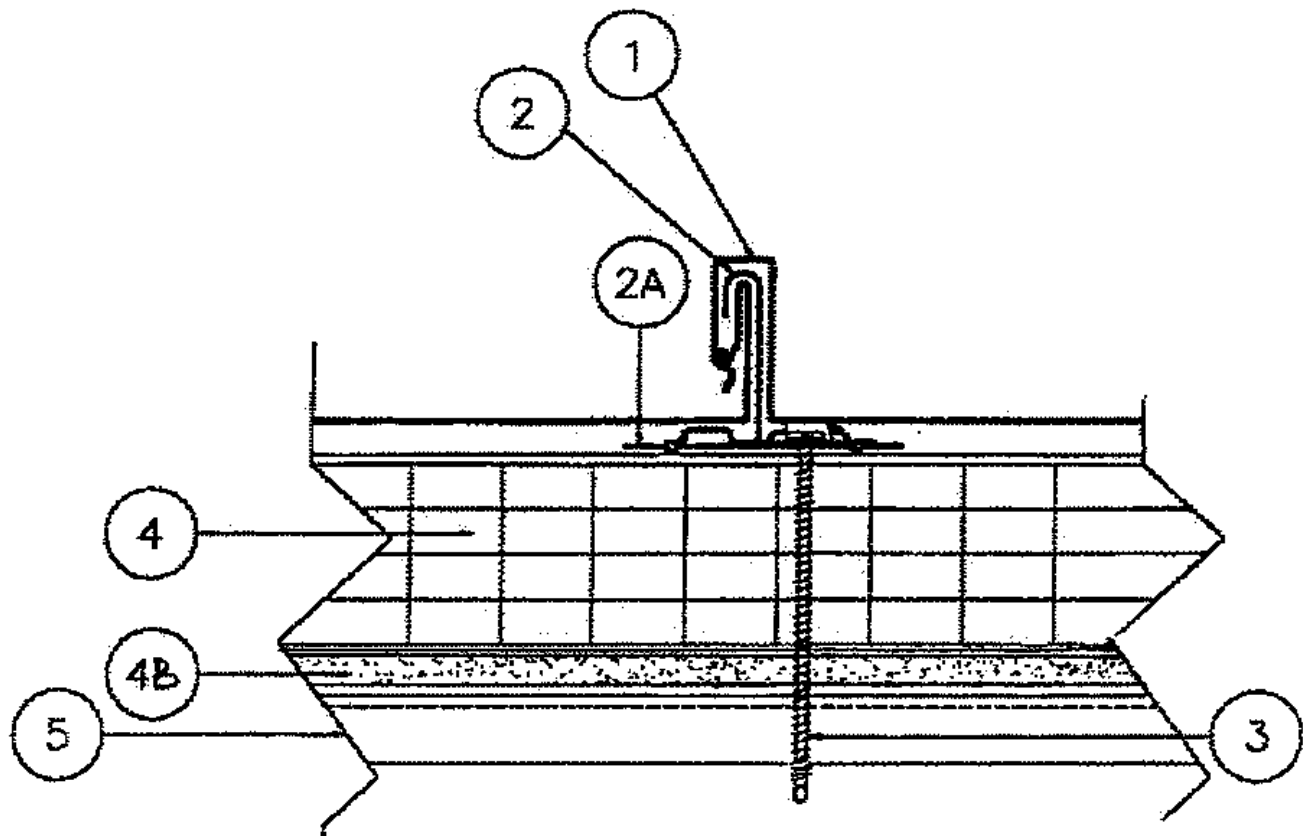

1. **Metal Roof Deck Panels*** — No. 24 MSG min thickness coated steel. Panel width 18 in. max., 10 in. min. ribs height 1-3/4 in. at female side. Panels continuous over three or more clips with no end laps. A bead of sealant may be used at panel side joints.

A & S BUILDING SYSTEMS LP — "LokSeam 10, 12 or 18"

AEP SPAN, DIV OF

ASC PROFILES — "18 in. Snap-Seam"; "12 in. Snap-Seam"; "10 in. Snap-Seam"

AMERICAN BUILDINGS CO — "Seam-Loc -12, -16, -18"

ARCHITECTURAL BUILDING COMPONENTS INC — "Permaseam Panel-12 or -18"

ARS INDUSTRIES INC — "US 175LS"

ATAS INTERNATIONAL INC — "K-Lok Structural Panel"

CENTRIA — "SDP 175-12, -16, -18"

COASTAL METAL SERVICE — "EZ Loc"

**CONSOLIDATED METALS OF FLORIDA, DIV OF
ALUMINUM SERVICE INC — "CSL-675"**

CONSTRUCTION METAL PRODUCTS INC — "CMP Series 2000"

DALEY CONSTRUCTION & METAL ROOFING — "3D Super Snap"

ENGLERT INC — "Series 2000"

HI-TEC ROOFING INC — "MRS 210A"

MADDOX ROOFING & CONSTRUCTION INC — "SS675 SNAP-LOK"

MBCI — "LokSeam 10, -12 or -18"

MESCO METAL BUILDINGS — "LokSeam 10, 12 or 18"

METAL-FAB MFG LLC — "MetFab Snap-On 675"

METAL ROOF COMPONENTS INC — "Snap Tite 175"

METAL ROOFING SYSTEMS INC — "MRS System 2000"

METAL PANEL SYSTEMS INC — "MP-175"

METAL SALES MFG CORP — " Vertical Seam"

METAL SOLUTIONS INC — "SL-175 Snap Lock Panel"

MORIN CORP — "SWL-12", "SWL-16", "SWL-18"

NCI BUILDING SYSTEMS L P — "LokSeam 10, 12 or 18"

NEW TECH MACHINERY CORP — "Snap Panel 675"

PETERSEN ALUMINUM CORP — "Snap-Clad"

PREMIUM PANELS INC — "SS675"

ROLLCOM — "SDP175-12 in., SDP175-16 in., SDP175-18 in."

SOUTHEASTERN METALS MANUFACTURING CO — "Verti-Lok"

STEELOX SYSTEMS L L C — "LS-175"

T T & L SHEET METAL INC — "Earl 300"

WHIRLWIND STEEL BUILDINGS INC — "Weather Snap-12" or "Weather Snap-16"

1A. Metal Roof Deck Panels* — (Not Shown) — To be used with Roof Deck Fastener (2E). 0.032 in. min thick aluminum, 16 in. wide, 1-3/4 in. high at the rib. Panels continuous over three or more clips with no end laps. A bead of sealant may be used at panel side joints.

PETERSEN ALUMINUM CORP — "Snap-Clad"

2. Roof Deck Fasteners* (Panel Clips) — One piece assembly, No. 24 MSG min thickness, 3-1/2 in. wide, 1-15/16 in. high. Clip spacing to be 48 in. OC. Clips to interface with Item 2A (bearing plate).

AEP SPAN, DIV OF

ASC PROFILES — "Snap-Seam Clip"

ARCHITECTURAL BUILDING COMPONENTS INC — "Permaseam Clip"

ARCHITECTURAL METAL SPECIALTIES INC — "178-SLU-18-G" and "178-SLP-18-G"

ATAS INTERNATIONAL INC — "K-Lok Structural Clip"

CENTRIA — "C175"

COASTAL METAL SERVICE — "EZ Loc Panel Clip"

LOGAN STAMPINGS INC — "Snap Lock Clip No. 675"

NCI BUILDING SYSTEMS L P — "Lock-Seam UL 90 Clip"

METAL PANEL SYSTEMS INC — "MP-175 Clip"

METAL SALES MFG CORP — " Vertical Seam Clip"

MORIN CORP — "SWL Clip"

PETERSEN ALUMINUM CORP — "Snap-Clad Clip"

ROLLCOM — "C175"

STEELOX SYSTEMS L L C — "LS-175 Clip"

2A. Roof Deck Fasteners* (Bearing Plate) — One piece assembly, No. 24 MSG min thickness steel, 4-1/2 in. wide, 6 in. long.

AEP SPAN, DIV OF

VP BUILDINGS — "Snap-Seam Plate".

2B. Bearing Plate-(Not Shown) — To be used with "Lock-Seam UL 90 Clip", "Permaseam Clip", "K-Lok Structural Clips" or "MP-175 Clip" only, (Item 2). Bearing plates to be 16 MSG min coated steel, 3-7/8 wide by 5 in long (50,000 psi min yield strength).

2C. **Bearing Plate*** — (Not Shown) — To be used with "Snap-Clad Clips" only (Item 2). To be 24 MSG thick coated steel, nom 4-5/8 in. wide by 6 in. long.

PETERSEN ALUMINUM CORP — "Snap-Clad Bearing Plate".

2D. **Bearing Plate** — (Not Shown) — To be used with "Vertical Seam Clip" only (Item 2) — Flat plate, 4 in. wide, 5 in. long fabricated from No. 20 MSG coated steel. Two 1/4 in. diam guide holes located to accommodate panel clip screw fasteners. (50,000 psi min yield strength).

2E. **Roof Deck Fasteners* (Panel Clips)** — (Not Shown) — One piece assembly, 3-1/2 in. wide, 1-7/8 in high with a 1-3/8 in. wide horizontal leg. No. 18 MSG min thick coated steel. Two 1/4 in. guide holes located in horizontal leg. Clips spaced 18 in. OC.

PETERSEN ALUMINUM CORP — "Snap-Clad Clip"

3. **Panel Fasteners — (Screws)** — Fasteners used to attach panel clips and bearing plates (Items 2 & 2A) through rigid insulation and optional OSB and/or gypsum board and into light gauge steel deck (Item No. 5) to be No. 14 truss head type with No. 3 Phillips drive, self-drilling steel screws. Two screws per clip to be used, inserted through 1/4 in. diam guide holes. Fasteners to penetrate liner panel 3/4 in. min.

3A. **Panel Fasteners (Screws)** — (Not Shown) — For Steelox Systems L L C, as an alternate, when no Rigid Insulation (Item 4) is used, No. 10-16 by min 1 in. long TEK 3 Carbon pancake head, self-drilling, self-tapping screws to be used. When rigid insulation is used, No. 14-13 by varying lengths, DP1, carbon, pancake-head, Square/Phillips Head screws to be used. Two fasteners per clip to be used for either type.

4. **Foamed Plastic — (Rigid Insulation)** — Min thickness 1 in., max thickness 4-1/2 in. Density to be a min of 1.8 pcf. or see products Classified under TJBX Category. Note: For Steelox Systems L L C, rigid insulation may be omitted. See Item 3A for fastener type.

4A. **Oriented Strand Board (OSB)** — (Optional) — (Not Shown) — Located over foamed plastic (Item 4). Max thickness 7/16 in. Note: Bearing plates not required when OSB is used.

4B. **Gypsum Board** — (Optional) — Max thickness 5/8 in. Located over liner panel (Item 5).

4C. **Foamed Plastic* (optional) (Not Shown)** — Rigid Foamed Plastic Insulation, "Foamular Thermapink 18" or "Foamular Thermapink 25", loose laid or mechanically fastened in one or more layers. Total thickness of insulation not to exceed 8 in.

OWENS CORNING SPECIALTY &

FOAM PRODUCTS

5. **Liner Panel** — Min thickness No. 22 MSG. Coated steel (33000 psi) min yield strength min depth 1-1/2 in., max pitch 6 in. fabricated to various profiles.

6. **Underlayment** — (Not shown) — One ply of 30 lb roofing felt or one layer of bituminous resin type water proofing membrane.

7. **Supports (Not Shown)** — Used to support liner panels, spaced per deck manufacturer's specifications for uplift.

The following items may be used in conjunction with the "AEP SPAN" Metal Roof Deck Panels (Item 1). When used, the panel system is identified as "SNAP-SEAM (SBS)".

A. **Batten Clips*** — Slipped over ribs formed by roof deck panels. One piece assembly, 1-3/4 in. high, 1-3/4 in. max width, with four legs and two arms. Formed to engage ribs of AEP SPAN Panels and Batten Cap (Item B). Clips spaced 48 in. OC.

AEP SPAN, DIV OF

ASC PROFILES — "SNAP-SEAM (SBS) Clip"

B. **Batten Cap*** — Slipped over batten clip. Two inches high 1-1/2 in. wide at top with sides formed to engage batten clip. Snapped over batten clips.

AEP SPAN, DIV OF

ASC PROFILES — "SNAP-SEAM (SBS) Batten"

The following items may be used in conjunction with the "K-Lok Structural Panel" (Item 1).

A. **Batten Clips*** — Slipped over ribs formed by roof deck panels. One piece assembly formed to engage ribs of "K-Lok Structural Panels (Item 1) and Batten Cap (Item B). Spaced 48 in. OC.

ATAS INTERNATIONAL INC — "K-Lok Structural Batten Clip"

B. **Batten Cap*** — Slipped over batten clip (Item A) and formed to snap and engage batten clip.

ATAS INTERNATIONAL INC — "K-Lok Structural Batten"

The following items may be used in conjunction with the "Design-Lok" panel (Item 1).

A. **Batten Clips*** — Slipped over ribs formed by roof deck panels. One piece assembly formed to engage ribs of "Design-Lok" panels (Item 1) and "Design-Lok Batten Cap" (Item B) spaced 48 in. OC.

METAL SALES MFG CORP — " Vertical Seam Batten Clip".

B. **Batten Cap*** — Slipped over batten clip (Item A), formed to snap over and engage batten clip.

METAL SALES MFG CORP — " Vertical Seam Batten Cap ".

The following items may be used in conjunction with the "Structural Standing Seam" panel and a Classified Batten Clip as described in this construction.

A. **Snap-on-Batten** — Slipped over a Classified Batten Clip, formed to snap over and engage batten clip.

The following items may be used in conjunction with the "SDP 175-12, -16, -18" panels. (Item 1).

A. **Batten Clips*** — Slipped over ribs formed by roof deck panels. One piece assembly formed to engage ribs of "SDP 175-12, -16, -18" panels. (Item 1) and "SDP 175B" battens (Item B). Spaced 48 in. OC.

CENTRIA — "175B".

ROLLCOM — "175B"

B. **Batten Cap*** — Slipped over batten clip (Item A) and formed to snap and engage batten clip.

CENTRIA — "SDP 175B".

ROLLCOM — " SDP 175B"

Refer to General information, Roof Deck Constructions for items not evaluated.

*Bearing the UL Classification Mark

[Page Top](#)

[Notice of Disclaimer](#)

[Questions?](#)

[Previous Page](#)

[UL Listed and Classified
Products](#)

[UL Recognized
Components](#)

[Products Certified for
Canada](#)

This page and all contents are Copyright © 2004 by Underwriters Laboratories Inc.®

The appearance of a company's name or product in this database does not in itself assure that products so identified have been manufactured under UL's Follow-Up Service. Only those products bearing the UL Mark should be considered to be Listed and covered under UL's Follow-Up Service. Always look for the Mark on the product.

UL permits the reproduction of the material contained on UL's Website subject to the following conditions: 1. The Guide Information, Designs and/or Listings (files) must be presented in their entirety and in a non-misleading manner, without any manipulation of the data (or drawings). 2. The statement "Reprinted from the Online Certifications Directory with permission from Underwriters Laboratories Inc." must appear adjacent to the extracted material. In addition, the reprinted material must include a copyright notice in the following format: "Copyright © 2004 Underwriters Laboratories Inc.®"



Online Certifications Directory

TGKX.343 Roof Deck Constructions

[Page Bottom](#)

[Questions?](#)

[Previous Page](#)

Roof Deck Constructions

Guide Information

Construction No. 343

March 11, 2004

Uplift — Class 90

Fire Not Investigated

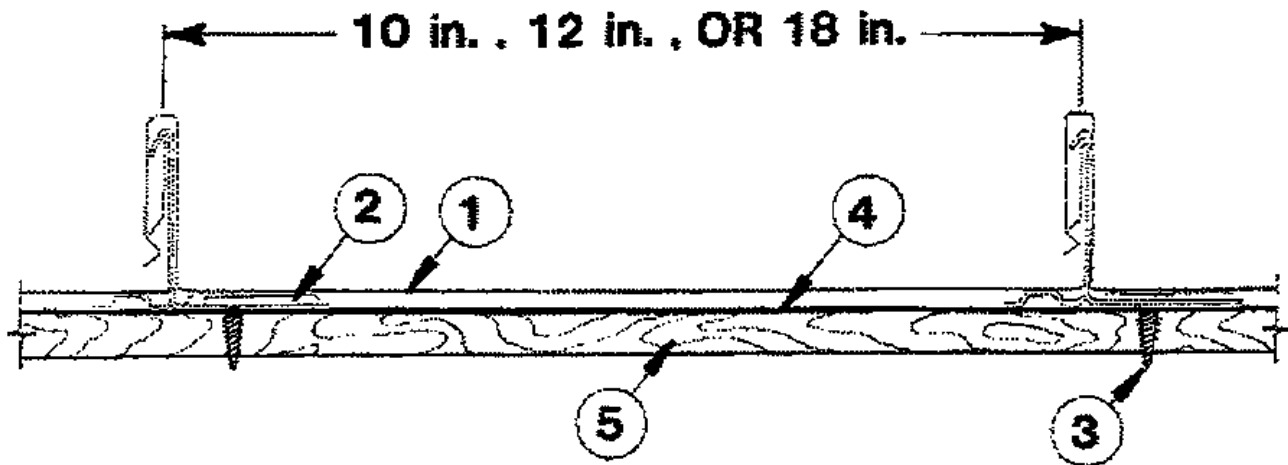

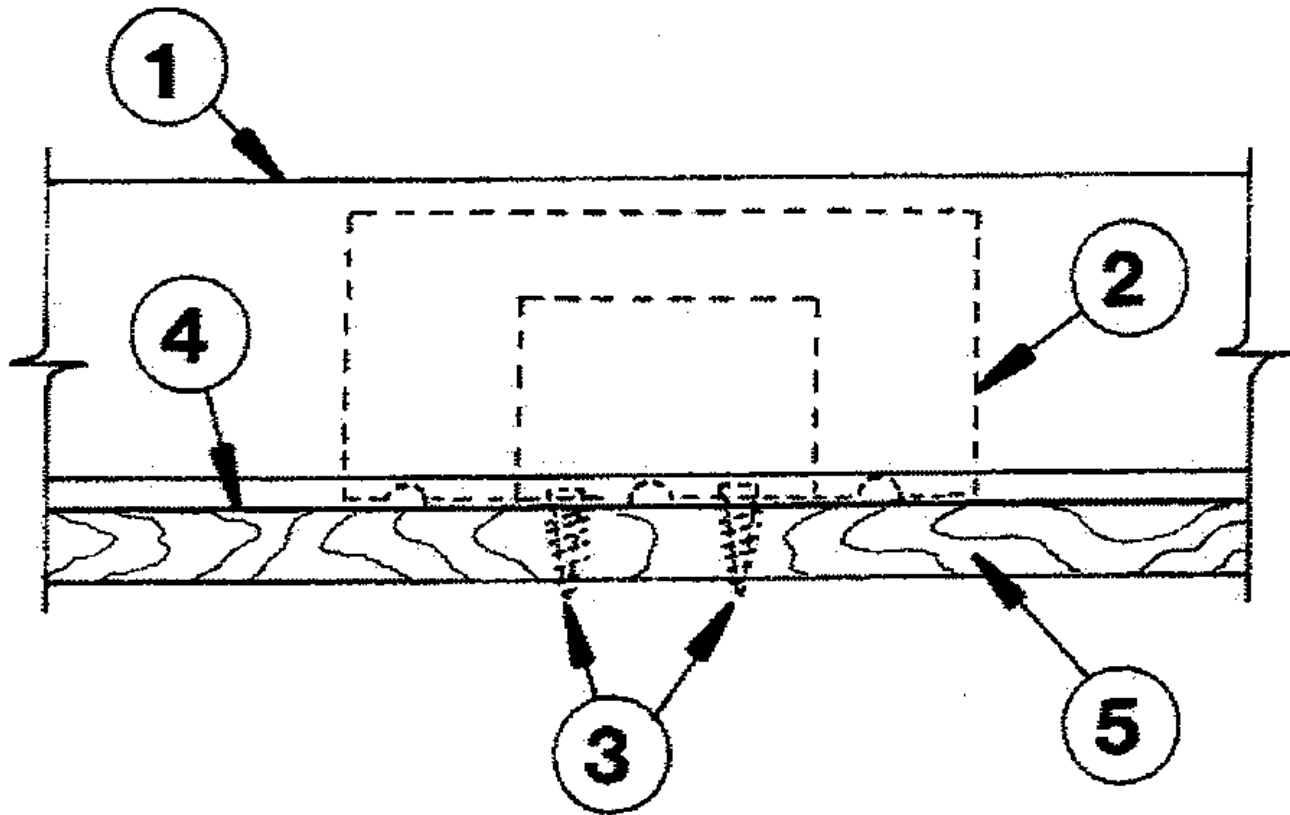

1. **Metal Roof Deck Panels*** — No. 24 MSG min coated steel. Panel width 18 in. max., 10 in. min. Rib height 1-3/4 in. at female side. Panels continuous over three or more clips with no endlaps. A bead of sealant may be used at panel side joints.

A & S BUILDING SYSTEMS L P — "LokSeam"

AEP SPAN, DIV OF

ASC PROFILES — "10 in. — Snap-Seam", "12 in. — Snap-Seam", "18 in. — Snap-Seam"

AMERICAN ARCHITECTURAL METAL MFG INC — "TL1750"

AMERICAN BUILDINGS CO — "SeamLoc 12, 16, 18"

ARCHITECTURAL BUILDING COMPONENTS INC — "Permaseam"

ATAS INTERNATIONAL INC — "K-Lok Structural Panel"

CENTRIA — "SDP 175-12, -16, -18"

COASTAL METAL SERVICE — "EZ Loc"

CSC SALES INC — "CSC-SL1750"

F A TAYLOR & SON INC — "SL1750"

MADDOX ROOFING & CONSTRUCTION INC — "SS675 SNAP-LOK"

MBCI — "LokSeam"

MCELROY METAL MILL INC — "Medallion-Lok" or "Metalogic-2000"

MESCO METAL BUILDINGS — "LokSeam"

METAL PANEL SYSTEMS INC — "MP-175"

METAL ROOF COMPONENTS INC — "Snap Tite 175"

METAL ROOFING SYSTEMS INC — "MRS System 2000"

METAL SALES MFG CORP — "Vertical Seam"

METAL WORX SYSTEMS INC — "SL1750"

MORIN CORP — "SWL-12", "SWL-16", "SWL-18"

NCI BUILDING SYSTEMS L P — "LokSeam"

NEW TECH MACHINERY CORP — "SS675"

PETERSEN ALUMINUM CORP — "Snap-Clad"

PREMIUM PANELS INC — "SS675"

ROLLCOM — "SDP 175-12, SDP 175-16, SDP 175-18"

R S S P INC — "SS1750"

SOUTHEASTERN METALS MANUFACTURING CO — "Verti-Lok"

STEELOX SYSTEMS L L C — "LS-175"

ULTRA SEAM INC — "US 175 LS"

WHIRLWIND STEEL BUILDINGS INC — "Weather Snap-12" or "Weather Snap-16"

ZIMMERMAN METALS INC — "SL1750"

2. Roof Deck Fasteners*(Panel Clips) — One piece assembly, 3-1/2 in. wide, 1-7/8 in. high. Min thickness No. 18 MSG. Clips spaced 36 in. OC, max, fastened to plywood deck.

AEP SPAN, DIV OF

ASC PROFILES — "Snap Seam Clip"

ARCHITECTURAL METAL SPECIALTIES INC — "178-SLU-18-G" and "178-SLP-18-G"

ATAS INTERNATIONAL INC — "K-Lok Structural Clip"

CENTRIA — "C175"

COASTAL METAL SERVICE — "EZ Loc Panel Clip"

ENGLERT INC — "Series 2000 Clip"

MCELROY METAL MILL INC — "Medallion-Lok Clip"

METAL PANEL SYSTEMS INC — "MP-175 Clip"

METAL SALES MFG CORP — "Vertical Seam Clip"

MORIN CORP — "SWL Clip"

NCI BUILDING SYSTEMS L P — "LokSeam UL 90 Clip"

PETERSEN ALUMINUM CORP — "Snap-Clad Clip"

ROLLCOM — C175

STEELOX SYSTEMS L L C — "Design-Lok Clip"

STEELOX SYSTEMS L L C — "LS-175 Clip"

3. Fasteners (Screws) — Fasteners used to attach panel clips (Item 2) to plywood to be No. 10-12 by 1 in. long pancake head, No. 2 Phillips drive, A-point, coated steel screw. Min two fasteners per clip to be used. When Items 5A (Rigid Insulation) and 5B (Bearing Plate) are used, No. 12 Dekfast fastener to be used and installed through clip (Item 2), bearing plate (Item 5B), rigid insulation (Item 5A) and plywood decking (Item 5A). Length of fastener to be equal to total thickness plus 7/8 in.

4. Underlayment — Underlayment used over plywood deck to be Type 15 or 30 organic felt. Sides overlapped min 2 in., end laps per manufacturer's instructions. Felt nailed to plywood deck with 1-1/4 in. long steel cap nails, located per manufacturer's instructions. Nail spacing to be max 12 in. OC at the side lap and max 24 in. OC in interior rows. **As An Alternate —** A self-adhering modified bitumen water proofing membrane may be used, installed per manufacturer's instructions. Note - when alternate is used the plywood joints need not be sealed.

5. Plywood Decking — Plywood decking to be graded per PS83 specifications, 19/32 in. thick, exposure 1, APA Rated Sheathing (42/20) square edged. Butt ends not blocked. All butt and side joints to be sealed with a one part urethane caulk sealant applied with a caulking gun and feathered outward from the joint. (Note exception under Item No. 4, Alternate.)

5A. Rigid Insulation (Optional) — (Not Shown) - Maximum thickness 1-1/2 in. Any rigid type having a minimum compressive strength of 25 psi or minimum density of 2 pcf. Supplied in 4 ft. wide sheets.

5B. Bearing Plate (Optional) — (Not Shown) - To be used with Item 5A. Bearing plates to be minimum 16 MSG coated steel. Located under each clip (Item 2) for support.

5C. Oriented Strand Board (OSB) — (Not Shown) - As an alternate decking, nom. 5/8 in. thick (19/32 in. actual) APA rated OSB may be substituted for plywood decking (Item 5). Installation procedures to be same as for plywood.

6. Supports — (Not Shown)—Spaced max of 24 in. OC. Any of the following types may be used to support the plywood decking:

- a) Nom 2 by 6 in., No. 2 grade or better S-P-F, Hemlock Fir, Douglas Fir or Southern Yellow Pine or equivalent.
- b) Wood trusses with a nom 2 by 4 in. upper chord of the same grade as item a.
- c) No. 22 MSG min cold formed coated steel (min yield to be 33,000 psi).

7. Plywood Fasteners — (Not Shown)—Fasteners used to attach the plywood deck or OSB to the supports to be as follows:

- a) For plywood-to-wood supports No. 8-18 by 1-7/8 in. long bugle-head steel screws with a No. 2 Phillips drive, a "Hi-Low" thread pattern and an "S-Point".
- b) As an alternate to Item a, 8d common ring shanked nails may be used.
- c) For plywood-to-steel supports for a steel thickness less than No. 20 MSG No. 7-19 by 1-1/4 in. long bugle-head steel screws with a No. 2 Phillips head drive "Hi-Low" threads and an "S-Point". For a steel thickness greater than No. 20 MSG to No. 16 MSG, No. 6-20 by 1-1/4 in. long bugle-head steel screws with a No. 2 Phillips drive and a S12 (TEKS/3)supR point.

Spacing: Fastener spacing for all fastener types to be 6 in. OC at the plywood edges and 12 in. OC in the interior.

The following items may be used in conjunction with the "AEP SPAN" Metal Roof Deck Panels (Item 1). When used, the panel system is identified as "SNAP-SEAM (SBS)".

A. Batten Clips* — Slipped over ribs formed by roof deck panels. One piece assembly, 1-3/4 in. high, 1-3/4 in. max width, with four legs and two arms. Formed to engage ribs of AEP SPAN Panels and Batten Cap (Item 6). Clips spaced 48 in. OC.

AEP SPAN, DIV OF**ASC PROFILES — "SNAP-SEAM (SBS) Clip"**

B. Batten Cap* — Slipped over batten clip. Two inches high 1-1/2 in. wide at top with sides formed to engage batten clip. Snapped over batten clips.

AEP SPAN, DIV OF**ASC PROFILES — "SNAP-SEAM (SBS) Batten"**

The following items may be used in conjunction with the "K-Lok Structural Panel" (Item 1).

A. Batten Clips* — Slipped over ribs formed by roof deck panels. One piece assembly formed to engage ribs of "K-Lok Structural Panels (Item 1) and Batten Cap (Item B). Spaced 48 in. O.C.

ATAS INTERNATIONAL INC — "K-Lok Structural Batten Clip".

B. Batten Cap* — Slipped over batten clip (Item A) and formed to snap and engage batten clip.

ATAS INTERNATIONAL INC — "K-Lok Structural Batten".

The following items may be used in conjunction with the "Design-Lok" panel (Item 1).

A. Batten Clips* — Slipped over ribs formed by roof deck panels. One piece assembly formed to engage ribs of "Design-Lok" panels (Item 1) and "Design-Lok Batten Cap" (Item B) spaced 48 in. OC.

METAL SALES MFG CORP — "Vertical Seam Batten Clip".

B. Batten Cap* — Slipped over batten clip (Item A), formed to snap over and engage batten clip.

METAL SALES MFG CORP — "Vertical Seam Batten Cap "

The following items may be used in conjunction with the "Structural Standing Seam" panel and a Classified Batten Clip as described in this construction.

A. Snap-on-Batten* — Slipped over a Classified Batten Clip, formed to snap over and engage batten clip.

The following items may be used in conjunction with the "LokSeam 18, 12 or 10 in." panel (Item 1).

A. Batten Clips — Slipped over ribs formed by roof deck panels. One piece assembly, 1-3/4 in. high, 1-3/4 in. max width, with four legs and two arms. Formed to engage ribs of panels and Batten Cap. Clips spaced 48 in. OC.

METAL BUILDING PRODUCTS INC — "SS-Large Batten Clip"

The following items may be used in conjunction with the "SDP 175-12, -16, -18" panels. (Item 1).

A. Batten Clips* — Slipped over ribs formed by roof deck panels. One piece assembly formed to engage ribs of "SDP-12, -16, -18" panels (Item 1) and "SDP 175B" battens (Item B). Spaced 48 in. OC.

CENTRIA — "175B"

ROLLCOM — "175B"

B. Batten Cap — Slipped over batten clip. (Item A) and formed to snap and engage batten clip.

CENTRIA — "SDP 175B"

ROLLCOM — "SDP 175B"

Refer to General information, Roof Deck Construction for items not evaluated.

*Bearing the UL Classification Mark

[Page Top](#)

[Notice of Disclaimer](#)

[Questions?](#)

[Previous Page](#)

[UL Listed and Classified Products](#)

[UL Recognized Components](#)

[Products Certified for Canada](#)

This page and all contents are Copyright © 2004 by Underwriters Laboratories Inc.®

The appearance of a company's name or product in this database does not in itself assure that products so identified have been manufactured under UL's Follow-Up Service. Only those products bearing the UL Mark should be considered to be Listed and covered under UL's Follow-Up Service. Always look for the Mark on the product.

UL permits the reproduction of the material contained on UL's Website subject to the following conditions: 1. The Guide Information, Designs and/or Listings (files) must be presented in their entirety and in a non-misleading manner, without any manipulation of the data (or drawings). 2. The statement "Reprinted from the Online Certifications Directory with permission from Underwriters Laboratories Inc." must appear adjacent to the extracted material. In addition, the reprinted material must include a copyright notice in the following format: "Copyright © 2004 Underwriters Laboratories Inc.®"



Online Certifications Directory

TGKX.508 Roof Deck Constructions

[Page Bottom](#)

[Questions?](#)

[Previous Page](#)

Roof Deck Constructions

Guide Information

Construction No. 508

November 21, 2003

Uplift-Class 90

Fire Not Investigated

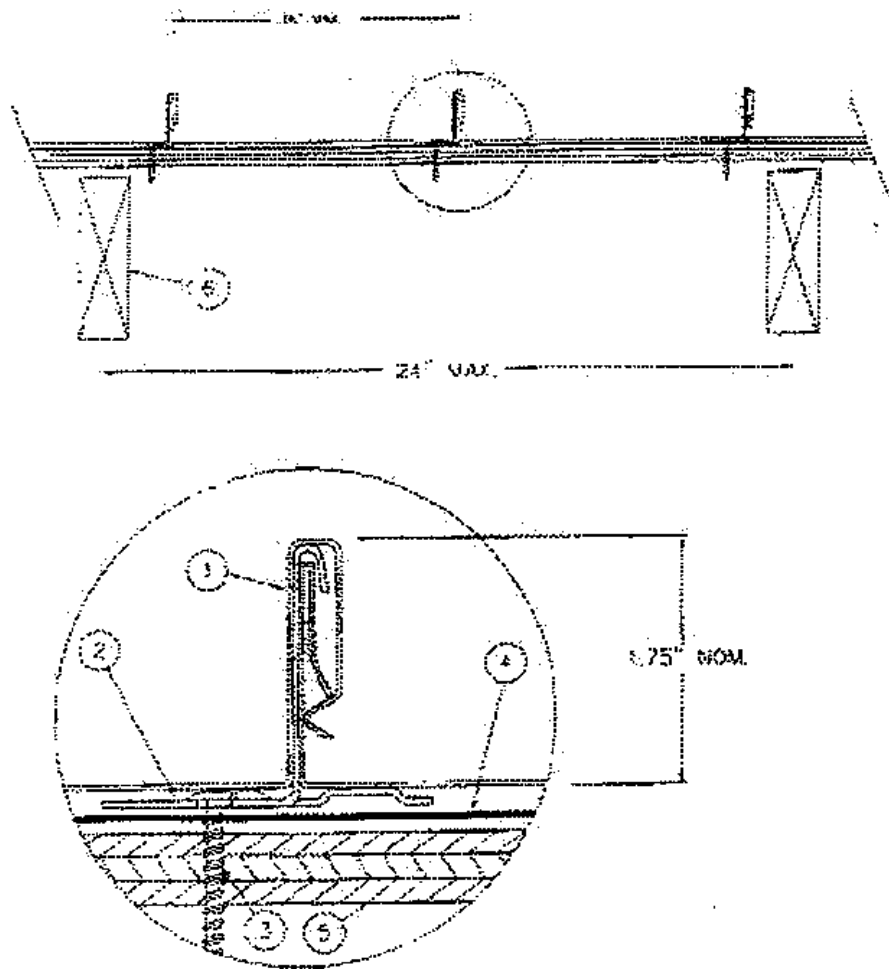

1. **Metal Roof Deck Panels*** — 0.032 in. min thick aluminum; 16 in. wide, 1-3/4 in. high at the rib. Panels continuous over three or more clips with no end laps. A bead of sealant may be used at panel side joints.

NEW TECH MACHINERY CORP — "SS 675"

PETERSEN ALUMINUM CORP — "Snap-Clad"

2. **Roof Deck Fasteners* (Panel Clips)** — One piece assembly, 3-1/2 in. wide, 1-7/8 in. high with a 1-3/8 in. wide horizontal leg. No. 18 MSG min thick coated steel. Two 1/4 in. guide holes located in horizontal leg. Clips spaced 18 in. OC.

PETERSEN ALUMINUM CORP — "Snap-Clad Clip"

3. **Panel Fasteners (Screws)** — Fasteners used to attach panel clips (Item 2) to plywood (Item 5) to be No. 10-12 by 1 in. long, No. 1 Phillips drive, bugle head coated steel wood screws. Two screws used per clip inserted through 1/4 in. diameter guide holes.

4. **Underlayment** — Underlayment used over plywood deck to be Type 30 organic felt. Sides overlapped min 2 in., end laps per manufacturer's instructions. Felt nailed to plywood deck with 1 in. long galvanized steel roofing nails, located per manufacturer's instructions. Nail spacing to be max 12 in. OC at the side lap and max 24 in. OC in interior rows.

5. **Plywood Decking** — Plywood decking to be graded per PS83 specification, 19/32 in. thick, exposure 1, APA rated sheathing (42/20) square edged. Butt ends not blocked.

6. **Supports** — Spaced max 24 in. OC. Any of the following types may be used to support the plywood decking:

a) 2 by 6 in., min No. 2 grade A.F.P.A. S-P-F Hemlock Fir, Douglas Fir or Southern Pine or equivalent.

b) Wood trusses with a nominal 2 by 4 in. upper chord of the same grade as Item a.

c) No. 22 MSG min thick cold formed coated steel (min yield strength to be 33,000 psi).

7. **Plywood Fasteners** — (Not Shown) — Fasteners used to attach the plywood deck to the supports to be as follows:

a) For plywood-to-wood supports, No. 8-18 by 1-7/8 in. long bugle-head steel screws with a No. 2 Phillips drive, a "Hi-Low" thread pattern and an "S-Point" .

b) As an alternate to Item a, 8d by 2-1/2 in. long deformed shank common nails may be used.

c) For plywood-to-steel supports for a steel thickness less than No. 20 MSG, No. 7-19 by 1-1/4 in. long bugle-head steel screws with a No. 2 Phillips head drive "Hi-Low" threads and an "S=Point" . For a steel thickness greater than No. 20 MSG to No. 16 MSG, No. 6-20 by 1-1/4 in. long bugle-head steel screws with a No. 2 Phillips drive and an S12 (TEKS/3) ® point.

Spacing: Fastener spacing for all fastener types to be 6 in. OC at the plywood edges and 12 in. OC in the interior.

Refer to General Information, Roof Deck Construction (Roofing Materials and Systems Directory) for items not evaluated.

*Bearing the UL Classification Mark

**UL Listed and Classified
Products****UL Recognized
Components****Products Certified for
Canada**

This page and all contents are Copyright © 2004 by Underwriters Laboratories Inc.®

The appearance of a company's name or product in this database does not in itself assure that products so identified have been manufactured under UL's Follow-Up Service. Only those products bearing the UL Mark should be considered to be Listed and covered under UL's Follow-Up Service. Always look for the Mark on the product.

UL permits the reproduction of the material contained on UL's Website subject to the following conditions: 1. The Guide Information, Designs and/or Listings (files) must be presented in their entirety and in a non-misleading manner, without any manipulation of the data (or drawings). 2. The statement "Reprinted from the Online Certifications Directory with permission from Underwriters Laboratories Inc." must appear adjacent to the extracted material. In addition, the reprinted material must include a copyright notice in the following format: "Copyright © 2004 Underwriters Laboratories Inc.®"



Online Certifications Directory

TGKX.508A Roof Deck Constructions

[Page Bottom](#)

[Questions?](#)

[Previous Page](#)

Roof Deck Constructions

Guide Information

Construction No. 508A

November 21, 2003

Uplift — Class 90

Fire Not Investigated

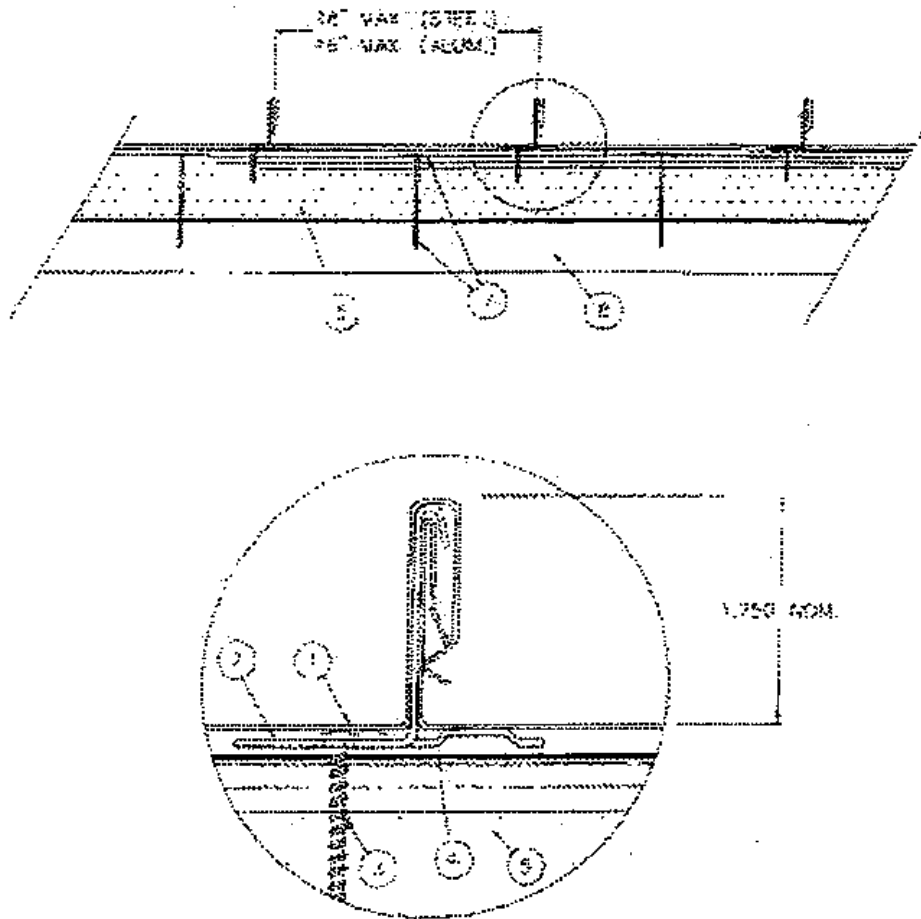

1. **Metal Roof Deck Panels*** — (when used with nailable insulation) No. 24 MSG min thick coated steel panels, 18 in., 16 in., 12 in. or 10 in. wide or 0.032 in. min thick aluminum, 16 in., 12 in. or 10 in. wide; 1-3/4 in. high at female side rib. Panels continuous over three or more clips with no end laps. A bead of sealant may be used at panel side joints.

CENTRIA — "SDP 175-12, -16, -18" (steel only)

PETERSEN ALUMINUM CORP — "Snap-Clad"

MBCI — "LokSeam"

METAL ROOFING SYSTEMS INC — "MRS System 2000"

NCI BUILDING SYSTEMS L P — "LokSeam"

NEW TECH MACHINERY CORP — "SS 675"

ROLLCOM — "SDP 175-12, -16, -18" (steel only)

WHIRLWIND STEEL BUILDINGS INC — "Weather Snap-12" or "Weather Snap-16"

1A. Metal Roof Deck Panels* — (When used with structural cement fiber unit) - No. 24 MSG min thick coated steel panels, 18 in, 16 in, 12 in, or 10 in wide, 1-3/4 high at female side rib. Panels continuous over three or more clips. Endlaps for panels to be overlapped 6 in. A bead of sealant may be used at panel ends and side joints.

MBCI — "LokSeam"

NCI BUILDING SYSTEMS L P — "LokSeam"

2. Roof Deck Fasteners* (Panel Clips) — One piece assembly, 3-1/2 in. wide, 1-7/8 in. high. No. 18 MSG min thick coated steel. Clips spaced 36 in. OC max for steel panels and 18 in. OC max for aluminum panels. Fastened to nailable insulation (Item 5).

CENTRIA — "C175"

PETERSEN ALUMINUM CORP — "Snap-Clad Clip"

NCI BUILDING SYSTEMS L P — "LokSeam UL90 Clips"

ROLLCOM — "C175"

2A. Roof Deck Fasteners* (Panel Clips) — One piece assembly, 3-1/2 in. wide, 1-7/8 in. high. No. 18 MSG min thick coated steel. Clips spaced 36 in. OC max for steel panels. Fastened to structural cement-Fiber unit

NCI BUILDING SYSTEMS L P — "LokSeam UL90 Clips"

3. Fasteners (Screws) — Fasteners used to attach panel clip (Item 2) to nailable insulation (Item 5), or structural cement-fiber units (Items 5A or 5D) to be No. 10-12 by 1 in. long pancake head, No. 2 Phillips drive, A-point, coated steel screws. Min two fasteners per clip.

4. Underlayment — Underlayment used over nailable insulation (Item 5) to be Type 30 organic felt. Sides overlapped min 2 in. End laps per manufacturer's instructions.

Felt nailed to nailable insulation with 1 in. long galvanized steel roofing nails, located in side laps and between side lap per manufacturer's instructions. Nail spacing to be max 12 in. OC at the side lap and max 24 in. OC in interior rows.

5. Nailable Insulation — Consisting of 1 in. min. to 3-1/2 in. max thick Classified polyisocyanurate foamed plastic with a factory laminated 7/16 in. thick APA rated O.S.B. Density of foamed plastic to be 2 pcf.

5A. Structural Cement-Fiber Unit (Substructure) (Not Shown) — (used in lieu of Nailable Insulation (Item 5) Consists of a minimum 5 in. thick composite structural cement-fiber units with foamed plastic core of a minimum 0.95 PCF density expanded polystyrene and 7/16 in OSB structural use panels on one face. All transverse butt joints are to occur over structural support. Unit will be designated as plank (tongue and groove) when used without truss tees (Item 5B). Unit will be designated as tile (rabbetted) when used with truss tees.

TECTUM INC — "Type E"

5B. Truss Tee — (Optional) (Not Shown) Minimum size to be 5-6-17-2. Maximum spacing to be 48-1/4 in. OC. Tees to be welded to structural support (Item 6) with a 3/4 in. fillet weld on both sides of tee.

5C. Tectum Grout — (Optional) (Not Shown) Used with truss tee (Item 5B) and tile (rabbetted) type substructure (Item 5A). Grout to fill void between substructure tiles around and above truss tee.

5D. Structural Cement-Fiber Unit (Substructure) — (Not Shown) (May be used in lieu of Item 5A) Consists of a minimum 5 in. thick composite structural cement-fiber units with foamed plastic core of a minimum 1.5 PCF density expanded polystyrene 7/16 in OSB structural use panels on one face. All transverse butt joints are to occur over structural support. Unit will be designated as plank (tongue and groove) when used without truss tees (Item 5B). Unit will be designated as tile (rabbetted) when used with truss tees.

TECTUM INC — "Type III"

6. Supports (Purlins) — (Not shown) — Purlins used for liner panel (Item 8) support to be cold formed steel sections. As alternatives, structural steel components (hot rolled beams, channels, open web joists, etc.) may be used. Min gauge and yield to depend on design considerations for uplift loading with max spacing to be 6 ft OC. As alternatives, structural steel components (hot rolled beams, channels, open web joists, etc.) may be used. Size and spacing of structural components to depend on design considerations.

7. Fasteners (Screws) — Fasteners used to attach nailable insulation (Item 5) to liner panel (Item 8) to be No. 11-13, No. 3 Phillips drive, truss head, painted steel screws. Length to depend on overall thickness of deck and to penetrate steel deck 1/2 in. min.

A 2 in. diameter formed pressure plate fabricated from No. 22 MSG coated steel to be used with each screw. Fasteners located in three rows along the 8 ft length of the nailable insulation beginning 6 in. from the 8 ft edges with a row down the center and spaced 21 in. OC beginning 6 in. from the 4 ft edges. A total of 15 fasteners used for each 4 by 8 ft board.

Fasteners used to attach Structural Cement Fiber Units (Items 5A or 5D) to structural support (Item 6) to be minimum 6 in. long, No. 14 screw with 5/8 in. diameter head. Fasteners are spaced a maximum of 12 in. OC at each joist along butt end. Pre-drilling with a 3/16 in. bit for steel up to 1/8 in. thick or with a 7/32 in. bit for steel greater than 1/8 in. thick when required.

8. Liner Panel (Steel Deck) (Optional when structural cement fiber units (items 5A or 5B) are used) — No. 22 MSG min thick coated steel. Min depth 1-1/2 in., max pitch 6 in. fabricated to various profiles. Min yield strength 33,000 psi. Fastened to supports (Item 6) with fastener type and spacing per liner panel manufacturers instructions for uplift loading.

9. Gypsum Board — (Optional) — (Not shown) — Max thick 5/8 in. supplied in 4 by 8 ft sheets. Butt joints located over crests of metal roof deck panel (Item 1). Fastened to panel with same fasteners used for nailable insulation (Item 5).

Refer to General Information, Roof Deck Construction (Roofing Materials and Systems Directory) for items not evaluated.

*Bearing the UL Classification Mark

[Page Top](#)

[Notice of Disclaimer](#)

[Questions?](#)

[Previous Page](#)

[UL Listed and Classified Products](#)

[UL Recognized Components](#)

[Products Certified for Canada](#)

This page and all contents are Copyright © 2004 by Underwriters Laboratories Inc.®

The appearance of a company's name or product in this database does not in itself assure that products so identified have been manufactured under UL's Follow-Up Service. Only those products bearing the UL Mark should be considered to be Listed and covered under UL's Follow-Up Service. Always look for the Mark on the product.

UL permits the reproduction of the material contained on UL's Website subject to the following conditions: 1. The Guide Information, Designs and/or Listings (files) must be presented in their entirety and in a non-misleading manner, without any manipulation of the data (or drawings). 2. The statement "Reprinted from the Online Certifications Directory with permission from Underwriters Laboratories Inc." must appear adjacent to the extracted material. In addition, the reprinted material must include a copyright notice in the following format: "Copyright © 2004 Underwriters Laboratories Inc.®"



JOHN F. BUTTS & ASSOC., INC.

CONSULTING ENGINEERS
2480 VANTAGE DRIVE COLORADO SPRINGS, CO 80919
(719) 598-7666 FAX (719) 598-0258

April 22, 1999

New Tech Machinery Corporation
1300 40th Street
Denver, CO 80205-3311

Re: Panel Analysis Report
New Tech SS150 Panel
New Tech SS200 Panel
New Tech SS210-A Panel
New Tech SS550 Panel
New Tech SS675 Panel
JFBA Job No. 183-04

Gentlemen:

Per your request, we have completed an analysis of the above referenced panels. The panels, with the structural properties indicated in this report, is certified to meet or exceed the requirements of the following design specifications:

American Iron and Steel Institute, *Specifications for the Design of Cold-Formed Steel Structural Members*, 1996 edition.

The following documents are enclosed for your records:

Panel cross-section
Panel analysis, pages 1 to 183
Panel Span Load tables, pages S1 to S71

Panels widths greater than 14 inches exceed the AISI allowable ratios for the panel width element. The AISI specifications, Section B1.1(a) states:

“...stiffened elements having w/t ratios larger than 500 can be used with adequate design strength to sustain the required loads; however; substantial deformations of such elements usually will invalidate the design equations of this specification.”

Before using the enclosed panel span tables, you will need to review the analysis reports for each panel. It is our opinion that the panels with w/t ratio elements exceeding 500 should be verified by testing before using the respective panel span tables.

Please note that the panel analysis and Load Tables have been evaluated based on the assumption that the proper bearing, side laps, end laps, bracing, anchorage and structural supports are being utilized in the member's installation. We do not certify the installation method, attachment and supporting materials.

If you have any questions, please call or write the undersigned.

Sincerely,



John F. Butts, PE
President



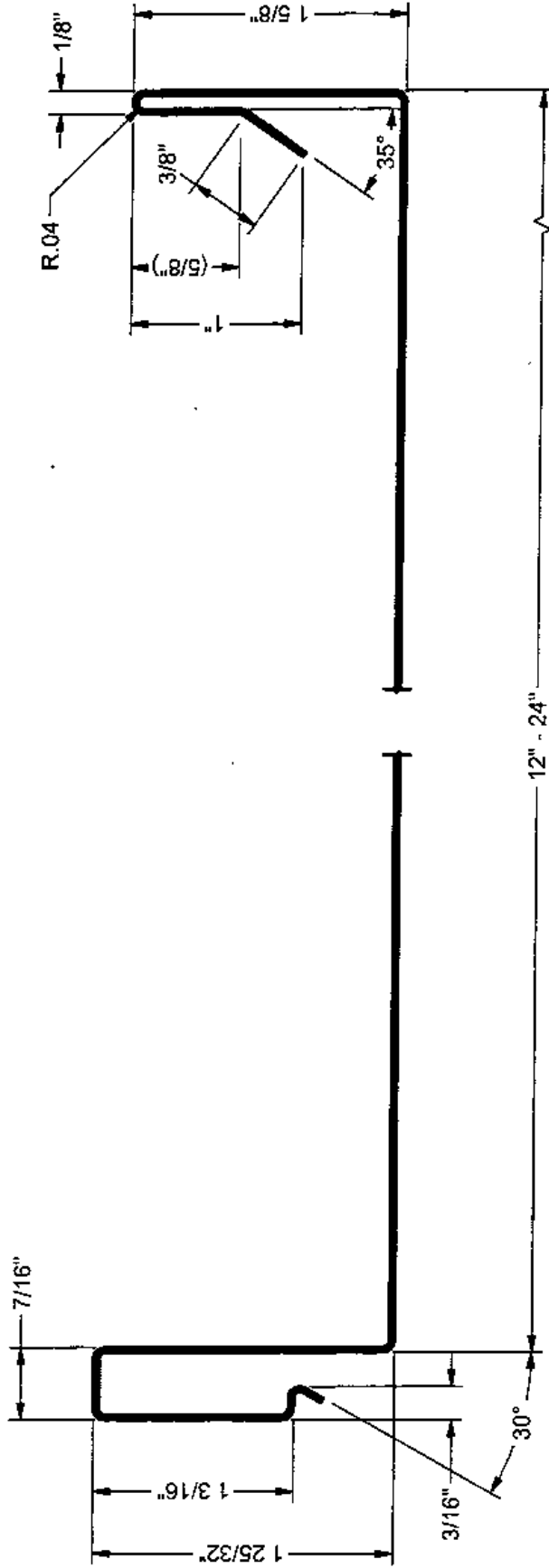
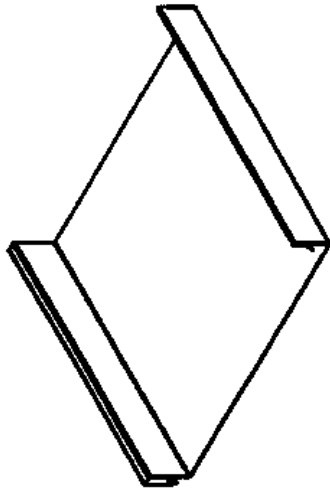

NOTE:
MATERIAL USAGE: 6 1/8"

REV		ECN NO.	DATE	RELEASED BY	FINISH	LENGTH	MATERIAL
0			7/2/02				
REVISION HISTORY							
TOLERANCES		XX = ± .01					
		XXX = ± .005					
		FRACTION = ± 1/32"					
		ANGLE = ± 1/2°					
DRAWN BY		SAWYER					
DATE		7/2/2002					
CHECK BY		A					
SIZE		1 OF 1					
SCALE		NONE					
PART NUMBER		SS675					
REVISION		0					

NEW TECH MACHINERY CORP.

SS675 PANEL PROFILE

John F. Butts & Associates, Inc.
2480 Vantage Drive
Colorado Springs, CO 80919
(719) 598-7666

PROFILE ANALYSIS & DESIGN

Per AISI Cold-Formed Steel
Design Manual, 1996 Edition

New Tech 675 Snap-On Panel

FILE NAME: NT675

DIMENSIONS

Line # 1 Angle (R) = -90.000 deg	Line # 1 Angle (L) = 90.000 deg
Radius (R) = 0.040 in	Radius (L) = 0.040 in
Length (R) = 1.487 in	Length (L) = 1.622 in
Line # 2 Angle (R) = 180.000 deg	Line # 2 Angle (L) = -90.000 deg
Radius (R) = 0.050 in	Radius (L) = 0.040 in
Length (R) = 0.525 in	Length (L) = 0.310 in
Line # 3 Angle (R) = 35.000 deg	Line # 3 Angle (L) = -90.000 deg
Radius (R) = 0.060 in	Radius (L) = 0.040 in
Length (R) = 0.349 in	Length (L) = 1.060 in
Line # 4 Angle (R) = 0.000 deg	Line # 4 Angle (L) = -90.000 deg
Radius (R) = 0.000 in	Radius (L) = 0.040 in
Length (R) = 0.000 in	Length (L) = 0.072 in
Line # 5 Angle (R) = 0.000 deg	Line # 5 Angle (L) = 120.000 deg
Radius (R) = 0.000 in	Radius (L) = 0.040 in
Length (R) = 0.000 in	Length (L) = 0.124 in

Panel Bottom Width = 11.872 in
Panel Overall Width = 12.000 in
Panel Overall Height = 1.750 in

Alloy: ASTM A653, G50
Fy = 50.00 ksi
Fv = 25.04 ksi

QUALIFICATIONS PER AISI SPECIFICATIONS

(a) Maximum w/t Ratio's Exceeded [SEC. B1.1(a)] | No
(b) Maximum h/t Ratio's Exceeded [SEC. B1.2(a)] | No

PROPERTIES FOR LOAD/SPAN TABLES

Aweb = 0.128 in ²	Sxp (per ft. of width) = 0.075 in ³
Sxp = 0.075 in ³	Sxn (per ft. of width) = 0.062 in ³
Sxn = 0.062 in ³	Ixp (per ft. of width) = 0.119 in ⁴
Ixp = 0.119 in ⁴	Ixn (per ft. of width) = 0.063 in ⁴
Ixn = 0.063 in ⁴	
Weight = 1.48 lb/lf	

New Tech 675 Snap-On Panel

Member - New Tech 675 Snap-On Panel								
Type	Name	Gage	Hgt (in)	Width (in)	Lip (in)	t (in)	Weight lb/ft	Coil Width (in)
Panel	PNL	24	1.750	12.000	0.000	0.0240	1.484	18.18
Gross Section Properties								
Area (in ²)	Ix (in ⁴)	Sx (in ³)	Rx (in)	Ycg (in)	Iy (in ⁴)	Sy (in ³)	Ry (in)	Xcg (in)
0.436	0.128	0.091	0.542	0.349	8.864	1.397	4.508	6.047
Effective Properties								
Ix (in ⁴)	Sx (in ³)	Iy (in ⁴)	Sy (in ³)	Mnx (in-k)	Mny (in-k)	Vnx (kip)	End Bearing Pne (kip) Pnei (k/in)	
0.119	0.075	0.000	0.000	3.09	0.00	3.210	0.558	0.491
Torsional Properties								
Xo (in)	Ro (in)	Beta	Cw (in ⁶)	Jv*1000 (in ⁴)	Fy (ksi)	Fu (ksi)	E (ksi)	G (ksi)
-0.880	4.624	0.964	3.22	0.084	50	65	29500	11300

Shear, moment and bearing values shown are nominal values and must be modified by the appropriate factors of safety (ASD) or resistance factors (LRFD).

Factors of Safety (ASD)		Resistance Factors (LRFD)	
Ω (Compression)	= 1.80	ϕ (Compression)	= 0.85
Ω (Tension)	= 1.67	ϕ (Tension)	= 0.95
Ω (Web Crippling)	= 1.85	ϕ (Web Crippling)	= 0.75
Ω (Bending)	= 1.67	ϕ (Bending)	= 1.11
Ω (Shear)	= 1.67	ϕ (Shear)	= 0.90

New Tech 675 Snap-On Panel

=====

Moment of Inertia @ 90 degree Rotation

ELEMENT	L	Y	LY	LYY	Io
1	0.082	12.383	1.011	12.525	0.0000
2	1.487	12.402	18.442	228.715	0.0000
3	0.195	12.340	2.404	29.660	0.0001
4	0.525	12.278	6.446	79.143	0.0000
5	0.044	12.274	0.540	6.626	0.0000
6	0.349	12.165	4.246	51.647	0.0012
14	11.872	6.414	76.147	488.407	139.4410
21	0.082	0.445	0.036	0.016	0.0000
22	1.622	0.426	0.691	0.294	0.0000
23	0.082	0.407	0.033	0.014	0.0000
24	0.310	0.219	0.068	0.015	0.0025
25	0.082	0.031	0.003	0.000	0.0000
26	1.060	0.012	0.013	0.000	0.0000
27	0.082	0.031	0.003	0.000	0.0000
28	0.072	0.100	0.007	0.001	0.0000
29	0.109	0.173	0.019	0.003	0.0001
30	0.124	0.150	0.019	0.003	0.0000
	18.177		110.126	897.069	139.4449

Ix = 8.864 in⁴
Ycg= 6.059 in

New Tech 675 Snap-On Panel

LOAD

ELEMENT VALUES FOR POSITIVE BENDING					
ELEMENT	L	Y	LY	LYY	Io
1	0.082	0.031	0.003	0.000	0.0000
2	1.487	0.808	1.201	0.970	0.2740
2a	-0.229	1.131	-0.259	-0.293	-0.0010
3	0.195	1.565	0.305	0.477	0.0000
4	0.525	1.288	0.676	0.872	0.0121
5	0.044	1.005	0.044	0.044	0.0000
6	0.280	0.870	0.244	0.212	0.0024
14	11.872	0.012	0.142	0.002	0.0000
21	0.082	0.031	0.003	0.000	0.0000
22	1.622	0.875	1.419	1.242	0.3556
22a	-0.409	1.180	-0.483	-0.570	-0.0057
23	0.082	1.719	0.140	0.241	0.0000
24	0.310	1.738	0.539	0.936	0.0000
25	0.082	1.719	0.140	0.241	0.0000
26	1.060	1.156	1.225	1.417	0.0993
26a	-0.527	1.109	-0.584	-0.648	-0.0122
27	0.082	0.593	0.048	0.029	0.0000
28	0.072	0.574	0.041	0.024	0.0000
29	0.109	0.544	0.059	0.032	0.0000
30	0.124	0.442	0.055	0.024	0.0001
	16.943		4.959	5.252	0.7246

Sx = 0.075 in³
 Ix = 0.109 in⁴
 Ycg = 0.293 in

Webs Fully Effective [SEC. B2.3(a)] | No

New Tech 675 Snap-On Panel

DEFLECTION

ELEMENT VALUES FOR POSITIVE BENDING

ELEMENT	L	Y	LY	LYY	Io
1	0.082	0.031	0.003	0.000	0.0000
2	1.487	0.808	1.201	0.970	0.2740
2a	-0.168	1.072	-0.180	-0.193	-0.0004
3	0.195	1.565	0.305	0.477	0.0000
4	0.525	1.288	0.676	0.872	0.0121
5	0.044	1.005	0.044	0.044	0.0000
6	0.349	0.842	0.294	0.247	0.0024
14	11.872	0.012	0.142	0.002	0.0000
21	0.082	0.031	0.003	0.000	0.0000
22	1.622	0.875	1.419	1.242	0.3556
22a	-0.082	1.250	-0.102	-0.128	-0.0000
23	0.082	1.719	0.140	0.241	0.0000
24	0.310	1.738	0.539	0.936	0.0000
25	0.082	1.719	0.140	0.241	0.0000
26	1.060	1.156	1.225	1.417	0.0993
26a	-0.303	1.153	-0.349	-0.403	-0.0023
27	0.082	0.593	0.048	0.029	0.0000
28	0.072	0.574	0.041	0.024	0.0000
29	0.109	0.544	0.059	0.032	0.0000
30	0.124	0.442	0.055	0.024	0.0001
	17.624		5.704	6.074	0.7408

Sx = 0.084 in³
 Ix = 0.119 in⁴
 Ycg = 0.324 in

Webs Fully Effective [SEC. B2.3(a)] | No

New Tech 675 Snap-On Panel

LOAD

ELEMENT VALUES FOR NEGATIVE BENDING					
ELEMENT	L	Y	LY	LYY	Io
1	0.082	0.031	0.003	0.000	0.0000
2	1.487	0.808	1.201	0.970	0.2740
2a	-0.022	0.328	-0.007	-0.002	-0.0000
3	0.195	1.565	0.305	0.477	0.0000
4	0.525	1.288	0.676	0.872	0.0121
5	0.044	1.005	0.044	0.044	0.0000
6	0.349	0.842	0.294	0.247	0.0024
14	1.137	0.012	0.014	0.000	0.0000
21	0.082	0.031	0.003	0.000	0.0000
22	1.622	0.875	1.419	1.242	0.3556
22a	-0.021	0.321	-0.007	-0.002	-0.0000
23	0.082	1.719	0.140	0.241	0.0000
24	0.310	1.738	0.539	0.936	0.0000
25	0.082	1.719	0.140	0.241	0.0000
26	1.060	1.156	1.225	1.417	0.0993
27	0.082	0.593	0.048	0.029	0.0000
28	0.072	0.574	0.041	0.024	0.0000
29	0.109	0.544	0.059	0.032	0.0000
30	0.124	0.442	0.055	0.024	0.0001
	7.399		6.193	6.792	0.7435

Sx = 0.062 in³
 Ix = 0.056 in⁴
 Ycg = 0.837 in

Webs Fully Effective [SEC. B2.3(a)] | No

New Tech 675 Snap-On Panel

DEFLECTION

ELEMENT VALUES FOR NEGATIVE BENDING					
ELEMENT	L	Y	LY	LYY	Io
1	0.082	0.031	0.003	0.000	0.0000
2	1.487	0.808	1.201	0.970	0.2740
3	0.195	1.565	0.305	0.477	0.0000
4	0.525	1.288	0.676	0.872	0.0121
5	0.044	1.005	0.044	0.044	0.0000
6	0.349	0.842	0.294	0.247	0.0024
14	1.528	0.012	0.018	0.000	0.0000
21	0.082	0.031	0.003	0.000	0.0000
22	1.622	0.875	1.419	1.242	0.3556
23	0.082	1.719	0.140	0.241	0.0000
24	0.310	1.738	0.539	0.936	0.0000
25	0.082	1.719	0.140	0.241	0.0000
26	1.060	1.156	1.225	1.417	0.0993
27	0.082	0.593	0.048	0.029	0.0000
28	0.072	0.574	0.041	0.024	0.0000
29	0.109	0.544	0.059	0.032	0.0000
30	0.124	0.442	0.055	0.024	0.0001
	7.833		6.211	6.797	0.7435

Sx = 0.066 in³
 Ix = 0.063 in⁴
 Ycg = 0.793 in

Webs Fully Effective [SEC. B2.3(a)] | Yes

New Tech 675 Snap-On Panel

MAXIMUM NOMINAL MOMENTS - [Section C3.1.1(a)]

Mnx [positive bending] = +3.726 k-in
Mnx [negative bending] = -3.092 k-in

MAXIMUM ALLOWABLE REACTIONS - [Table C3.4-1]

N/t = 83.33
k = 1.515
C1 = 0.887
C2 = 0.960
C3 = 0.830
C4 = 0.900
C9 = 1.000
C0 = 1.000 - Element 2, 22
C0 = 1.000 - Element 4
C0 = 1.000 - Element 26

Pend = $t^2 * k * C3 * C4 * C9 * C0 [331 - 0.61(h/t)] [0.71 + 0.015(N/t)]$
h/t = 61.96 | Pe(2) = 1 * 0.375 kips = 0.375 kips
h/t = 21.88 | Pe(4) = 1 * 0.406 kips = 0.406 kips
h/t = 67.58 | Pe(22) = 1 * 0.370 kips = 0.370 kips
h/t = 44.17 | Pe(26) = 1 * 0.389 kips = 0.389 kips
Pend = 1.539 kips

Pint = $t^2 * k * C1 * C2 * C9 * C0 [538 - 0.74(h/t)] [0.75 + 0.011(N/t)]$
h/t = 61.96 | Pi(2) = 1 * 0.609 kips = 0.609 kips
h/t = 21.88 | Pi(4) = 1 * 0.646 kips = 0.646 kips
h/t = 67.58 | Pi(22) = 1 * 0.604 kips = 0.604 kips
h/t = 44.17 | Pi(26) = 1 * 0.626 kips = 0.626 kips
Pint = 2.485 kips

MAXIMUM NOMINAL SHEAR - [Section C3.2]

E = 29,500 ksi
Fy = 50.00 ksi
kv = 5.34 - for unreinforced webs
0.960 * Sqr(Ekv/Fy) = 53.88
1.415 * Sqr(Ekv/Fy) = 79.42

h/t = 61.96 | V(2) = 1 * 1.035 kips = 1.035 kips (Eq. C3.2-2)
h/t = 21.88 | V(4) = 1 * 0.378 kips = 0.378 kips (Eq. C3.2-1)
h/t = 67.58 | V(22) = 1 * 1.035 kips = 1.035 kips (Eq. C3.2-2)
h/t = 44.17 | V(26) = 1 * 0.763 kips = 0.763 kips (Eq. C3.2-1)

Vn = 3.210 kips

New Tech 675 Snap-On Panel

Sheet Gauge = 0.0240 in, 24 gauge

PANEL ELEMENTS EXCEEDING AISI ALLOWABLE RATIOS

Element No. 14 : $w/t > 250$ -Actual $w/t = 495$

NOTE: AISI Specifications, Section B1.1(a) states

stiffened compression elements that have w/t ratios exceeding approximately 250 are likely to develop noticeable deformation at the full design strength, without affecting the ability of the member to develop the required strength.

John F. Butts & Associates, Inc.
2480 Vantage Drive
Colorado Springs, CO 80919
(719) 598-7666

PROFILE ANALYSIS & DESIGN

Per AISI Cold-Formed Steel
Design Manual, 1996 Edition

New Tech 675 Snap-On Panel

=====

FILE NAME: NT675

DIMENSIONS

Line # 1 Angle (R) = -90.000 deg	Line # 1 Angle (L) = 90.000 deg
Radius (R) = 0.040 in	Radius (L) = 0.040 in
Length (R) = 1.487 in	Length (L) = 1.622 in
Line # 2 Angle (R) = 180.000 deg	Line # 2 Angle (L) = -90.000 deg
Radius (R) = 0.050 in	Radius (L) = 0.040 in
Length (R) = 0.525 in	Length (L) = 0.310 in
Line # 3 Angle (R) = 35.000 deg	Line # 3 Angle (L) = -90.000 deg
Radius (R) = 0.060 in	Radius (L) = 0.040 in
Length (R) = 0.349 in	Length (L) = 1.060 in
Line # 4 Angle (R) = 0.000 deg	Line # 4 Angle (L) = -90.000 deg
Radius (R) = 0.000 in	Radius (L) = 0.040 in
Length (R) = 0.000 in	Length (L) = 0.072 in
Line # 5 Angle (R) = 0.000 deg	Line # 5 Angle (L) = 120.000 deg
Radius (R) = 0.000 in	Radius (L) = 0.040 in
Length (R) = 0.000 in	Length (L) = 0.124 in

Panel Bottom Width = 13.872 in
Panel Overall Width = 14.000 in
Panel Overall Height = 1.750 in

Alloy: ASTM A653, G50
 Fy = 50.00 ksi
 Fv = 25.04 ksi

QUALIFICATIONS PER AISI SPECIFICATIONS

(a) Maximum w/t Ratio's Exceeded [SEC. B1.1(a)] | No
(b) Maximum h/t Ratio's Exceeded [SEC. B1.2(a)] | No

PROPERTIES FOR LOAD/SPAN TABLES

Aweb = 0.128 in ²	Sxp (per ft. of width) = 0.064 in ³
Sxp = 0.074 in ³	Sxn (per ft. of width) = 0.053 in ³
Sxn = 0.062 in ³	Ixp (per ft. of width) = 0.107 in ⁴
Ixp = 0.125 in ⁴	Ixn (per ft. of width) = 0.054 in ⁴
Ixn = 0.063 in ⁴	
Weight = 1.65 lb/lf	

New Tech 675 Snap-On Panel

Member - New Tech 675 Snap-On Panel								
Type	Name	Gage	Hgt (in)	Width (in)	Lip (in)	t (in)	Weight lb/ft	Coil Width (in)
Panel	PNL	24	1.750	14.000	0.000	0.0240	1.648	20.18
Gross Section Properties								
Area (in ²)	Ix (in ⁴)	Sx (in ³)	Rx (in)	Ycg (in)	Iy (in ⁴)	Sy (in ³)	Ry (in)	Xcg (in)
0.484	0.133	0.093	0.524	0.315	12.833	1.745	5.148	7.035
Effective Properties								
Ix (in ⁴)	Sx (in ³)	Iy (in ⁴)	Sy (in ³)	Mnx (in-k)	Mny (in-k)	Vnx (kip)	End Bearing Pne (kip)	Pnei (k/in)
0.125	0.074	0.000	0.000	3.09	0.00	3.210	0.558	0.491
Torsional Properties								
Xo (in)	Ro (in)	Beta	Cw (in ⁶)	Jv*1000 (in ⁴)	Fy (ksi)	Fu (ksi)	E (ksi)	G (ksi)
-0.806	5.237	0.976	4.54	0.093	50	65	29500	11300

Shear, moment and bearing values shown are nominal values and must be modified by the appropriate factors of safety (ASD) or resistance factors (LRFD).

Factors of Safety (ASD)		Resistance Factors (LRFD)	
Ω (Compression)	= 1.80	ϕ (Compression)	= 0.85
Ω (Tension)	= 1.67	ϕ (Tension)	= 0.95
Ω (Web Crippling)	= 1.85	ϕ (Web Crippling)	= 0.75
Ω (Bending)	= 1.67	ϕ (Bending)	= 1.11
Ω (Shear)	= 1.67	ϕ (Shear)	= 0.90

New Tech 675 Snap-On Panel

Moment of Inertia @ 90 degree Rotation

ELEMENT	L	Y	LY	LYY	Io
1	0.082	14.383	1.175	16.898	0.0000
2	1.487	14.402	21.416	308.430	0.0000
3	0.195	14.340	2.793	40.053	0.0001
4	0.525	14.278	7.496	107.027	0.0000
5	0.044	14.274	0.628	8.961	0.0000
6	0.349	14.165	4.944	70.025	0.0012
14	13.872	7.414	102.847	762.508	222.4518
21	0.082	0.445	0.036	0.016	0.0000
22	1.622	0.426	0.691	0.294	0.0000
23	0.082	0.407	0.033	0.014	0.0000
24	0.310	0.219	0.068	0.015	0.0025
25	0.082	0.031	0.003	0.000	0.0000
26	1.060	0.012	0.013	0.000	0.0000
27	0.082	0.031	0.003	0.000	0.0000
28	0.072	0.100	0.007	0.001	0.0000
29	0.109	0.173	0.019	0.003	0.0001
30	0.124	0.150	0.019	0.003	0.0000
	20.177		142.189	1314.248	222.4557

Ix = 12.833 in⁴
 Ycg = 7.047 in

New Tech 675 Snap-On Panel

LOAD

ELEMENT VALUES FOR POSITIVE BENDING

ELEMENT	L	Y	LY	LYY	Io
1	0.082	0.031	0.003	0.000	0.0000
2	1.487	0.808	1.201	0.970	0.2740
2a	-0.265	1.111	-0.294	-0.327	-0.0016
3	0.195	1.565	0.305	0.477	0.0000
4	0.525	1.288	0.676	0.872	0.0121
5	0.044	1.005	0.044	0.044	0.0000
6	0.280	0.870	0.244	0.212	0.0024
14	13.872	0.012	0.166	0.002	0.0000
21	0.082	0.031	0.003	0.000	0.0000
22	1.622	0.875	1.419	1.242	0.3556
22a	-0.443	1.161	-0.514	-0.597	-0.0072
23	0.082	1.719	0.140	0.241	0.0000
24	0.310	1.738	0.539	0.936	0.0000
25	0.082	1.719	0.140	0.241	0.0000
26	1.060	1.156	1.225	1.417	0.0993
26a	-0.560	1.090	-0.610	-0.666	-0.0146
27	0.082	0.593	0.048	0.029	0.0000
28	0.072	0.574	0.041	0.024	0.0000
29	0.109	0.544	0.059	0.032	0.0000
30	0.124	0.442	0.055	0.024	0.0001
	18.840		4.890	5.174	0.7201

Sx = 0.074 in³
 Ix = 0.111 in⁴
 Ycg = 0.260 in

Webs Fully Effective {SEC. B2.3(a)} | No

New Tech 675 Snap-On Panel

DEFLECTION

ELEMENT VALUES FOR POSITIVE BENDING					
ELEMENT	L	Y	LY	LYY	Io
1	0.082	0.031	0.003	0.000	0.0000
2	1.487	0.808	1.201	0.970	0.2740
3	0.195	1.565	0.305	0.477	0.0000
4	0.525	1.288	0.676	0.872	0.0121
5	0.044	1.005	0.044	0.044	0.0000
6	0.349	0.842	0.294	0.247	0.0024
14	13.872	0.012	0.166	0.002	0.0000
21	0.082	0.031	0.003	0.000	0.0000
22	1.622	0.875	1.419	1.242	0.3556
22a	-0.104	1.234	-0.128	-0.158	-0.0001
23	0.082	1.719	0.140	0.241	0.0000
24	0.310	1.738	0.539	0.936	0.0000
25	0.082	1.719	0.140	0.241	0.0000
26	1.060	1.156	1.225	1.417	0.0993
26a	-0.330	1.137	-0.375	-0.427	-0.0030
27	0.082	0.593	0.048	0.029	0.0000
28	0.072	0.574	0.041	0.024	0.0000
29	0.109	0.544	0.059	0.032	0.0000
30	0.124	0.442	0.055	0.024	0.0001
	19.743		5.856	6.213	0.7405

Sx = 0.086 in³
 Ix = 0.125 in⁴
 Ycg = 0.297 in

Webs Fully Effective [SEC. B2.3(a)] No

New Tech 675 Snap-On Panel

LOAD

ELEMENT VALUES FOR NEGATIVE BENDING

ELEMENT	L	Y	LY	LYY	Io
1	0.082	0.031	0.003	0.000	0.0000
2	1.487	0.808	1.201	0.970	0.2740
2a	-0.021	0.327	-0.007	-0.002	-0.0000
3	0.195	1.565	0.305	0.477	0.0000
4	0.525	1.288	0.676	0.872	0.0121
5	0.044	1.005	0.044	0.044	0.0000
6	0.349	0.842	0.294	0.247	0.0024
14	1.142	0.012	0.014	0.000	0.0000
21	0.082	0.031	0.003	0.000	0.0000
22	1.622	0.875	1.419	1.242	0.3556
22a	-0.020	0.321	-0.006	-0.002	-0.0000
23	0.082	1.719	0.140	0.241	0.0000
24	0.310	1.738	0.539	0.936	0.0000
25	0.082	1.719	0.140	0.241	0.0000
26	1.060	1.156	1.225	1.417	0.0993
27	0.082	0.593	0.048	0.029	0.0000
28	0.072	0.574	0.041	0.024	0.0000
29	0.109	0.544	0.059	0.032	0.0000
30	0.124	0.442	0.055	0.024	0.0001
	7.406		6.193	6.792	0.7435

Sx = 0.062 in³
 Ix = 0.057 in⁴
 Ycg = 0.836 in

Webs Fully Effective [SEC. B2.3(a)] | No

New Tech 675 Snap-On Panel

DEFLECTION

ELEMENT VALUES FOR NEGATIVE BENDING

ELEMENT	L	Y	LY	LYY	Io
1	0.082	0.031	0.003	0.000	0.0000
2	1.487	0.808	1.201	0.970	0.2740
3	0.195	1.565	0.305	0.477	0.0000
4	0.525	1.288	0.676	0.872	0.0121
5	0.044	1.005	0.044	0.044	0.0000
6	0.349	0.842	0.294	0.247	0.0024
14	1.534	0.012	0.018	0.000	0.0000
21	0.082	0.031	0.003	0.000	0.0000
22	1.622	0.875	1.419	1.242	0.3556
23	0.082	1.719	0.140	0.241	0.0000
24	0.310	1.738	0.539	0.936	0.0000
25	0.082	1.719	0.140	0.241	0.0000
26	1.060	1.156	1.225	1.417	0.0993
27	0.082	0.593	0.048	0.029	0.0000
28	0.072	0.574	0.041	0.024	0.0000
29	0.109	0.544	0.059	0.032	0.0000
30	0.124	0.442	0.055	0.024	0.0001
	7.839		6.211	6.797	0.7435

Sx = 0.066 in³
 Ix = 0.063 in⁴
 Ycg = 0.792 in

Webs Fully Effective [SEC. B2.3(a)] | Yes

New Tech 675 Snap-On Panel

=====

MAXIMUM NOMINAL MOMENTS - [Section C3.1.1(a)]

Mnx [positive bending] = +3.723 k-in
Mnx [negative bending] = -3.094 k-in

MAXIMUM ALLOWABLE REACTIONS - [Table C3.4-1]

N/t = 83.33
k = 1.515
C1 = 0.887
C2 = 0.960
C3 = 0.830
C4 = 0.900
C9 = 1.000
C0 = 1.000 - Element 2, 22
C0 = 1.000 - Element 4
C0 = 1.000 - Element 26

Pend = $t^2 * k * C3 * C4 * C9 * C0 [331 - 0.61(h/t)] [0.71 + 0.015(N/t)]$
h/t = 61.96 | Pe(2) = 1 * 0.375 kips = 0.375 kips
h/t = 21.88 | Pe(4) = 1 * 0.406 kips = 0.406 kips
h/t = 67.58 | Pe(22) = 1 * 0.370 kips = 0.370 kips
h/t = 44.17 | Pe(26) = 1 * 0.389 kips = 0.389 kips
Pend = 1.539 kips

Pint = $t^2 * k * C1 * C2 * C9 * C0 [538 - 0.74(h/t)] [0.75 + 0.011(N/t)]$
h/t = 61.96 | Pi(2) = 1 * 0.609 kips = 0.609 kips
h/t = 21.88 | Pi(4) = 1 * 0.646 kips = 0.646 kips
h/t = 67.58 | Pi(22) = 1 * 0.604 kips = 0.604 kips
h/t = 44.17 | Pi(26) = 1 * 0.626 kips = 0.626 kips
Pint = 2.485 kips

MAXIMUM NOMINAL SHEAR - [Section C3.2]

E = 29,500 ksi
Fy = 50.00 ksi
kv = 5.34 - for unreinforced webs
0.960 * Sqr(Ekv/Fy) = 53.88
1.415 * Sqr(Ekv/Fy) = 79.42

h/t = 61.96 | V(2) = 1 * 1.035 kips = 1.035 kips (Eq. C3.2-2)
h/t = 21.88 | V(4) = 1 * 0.378 kips = 0.378 kips (Eq. C3.2-1)
h/t = 67.58 | V(22) = 1 * 1.035 kips = 1.035 kips (Eq. C3.2-2)
h/t = 44.17 | V(26) = 1 * 0.763 kips = 0.763 kips (Eq. C3.2-1)

Vn = 3.210 kips

New Tech 675 Snap-On Panel

Sheet Gauge = 0.0240 in, 24 gauge

PANEL ELEMENTS EXCEEDING AISI ALLOWABLE RATIOS

Element No. 14 : $w/t > 500$ -Actual $w/t = 578$

NOTE: AISI Specifications, Section B1.1(a) states

stiffened elements having w/t ratios larger than 500 can be used with adequate design strength to sustain the required loads; however; substantial deformations of such elements usually will invalidate the design equations of this Specification.

John F. Butts & Associates, Inc.
2480 Vantage Drive
Colorado Springs, CO 80919
(719) 598-7666

PROFILE ANALYSIS & DESIGN

Per AISI Cold-Formed Steel
Design Manual, 1996 Edition

New Tech 675 Snap-On Panel

=====

FILE NAME: NT675

DIMENSIONS

Line # 1 Angle (R) = -90.000 deg	Line # 1 Angle (L) = 90.000 deg
Radius (R) = 0.040 in	Radius (L) = 0.040 in
Length (R) = 1.487 in	Length (L) = 1.622 in
Line # 2 Angle (R) = 180.000 deg	Line # 2 Angle (L) = -90.000 deg
Radius (R) = 0.050 in	Radius (L) = 0.040 in
Length (R) = 0.525 in	Length (L) = 0.310 in
Line # 3 Angle (R) = 35.000 deg	Line # 3 Angle (L) = -90.000 deg
Radius (R) = 0.060 in	Radius (L) = 0.040 in
Length (R) = 0.349 in	Length (L) = 1.060 in
Line # 4 Angle (R) = 0.000 deg	Line # 4 Angle (L) = -90.000 deg
Radius (R) = 0.000 in	Radius (L) = 0.040 in
Length (R) = 0.000 in	Length (L) = 0.072 in
Line # 5 Angle (R) = 0.000 deg	Line # 5 Angle (L) = 120.000 deg
Radius (R) = 0.000 in	Radius (L) = 0.040 in
Length (R) = 0.000 in	Length (L) = 0.124 in

Panel Bottom Width = 15.872 in
Panel Overall Width = 16.000 in
Panel Overall Height = 1.750 in

Alloy: ASTM A653, G50
Fy = 50.00 ksi
Fv = 25.04 ksi

QUALIFICATIONS PER AISI SPECIFICATIONS

(a) Maximum w/t Ratio's Exceeded [SEC. B1.1(a)] | No
(b) Maximum h/t Ratio's Exceeded [SEC. B1.2(a)] | No

PROPERTIES FOR LOAD/SPAN TABLES

Aweb = 0.128 in ²	Sxp (per ft. of width) = 0.056 in ³
Sxp = 0.074 in ³	Sxn (per ft. of width) = 0.046 in ³
Sxn = 0.062 in ³	Ixp (per ft. of width) = 0.096 in ⁴
Ixp = 0.128 in ⁴	Ixn (per ft. of width) = 0.047 in ⁴
Ixn = 0.063 in ⁴	
Weight = 1.81 lb/lf	

New Tech 675 Snap-On Panel

Member - New Tech 675 Snap-On Panel								
Type	Name	Gage	Hgt (in)	Width (in)	Lip (in)	t (in)	Weight lb/ft	Coil Width (in)
Panel	PNL	24	1.750	16.000	0.000	0.0240	1.811	22.18
Gross Section Properties								
Area (in ²)	Ix (in ⁴)	Sx (in ³)	Rx (in)	Ycg (in)	Iy (in ⁴)	Sy (in ³)	Ry (in)	Xcg (in)
0.532	0.137	0.094	0.507	0.288	17.770	2.124	5.778	8.026
Effective Properties								
Ix (in ⁴)	Sx (in ³)	Iy (in ⁴)	Sy (in ³)	Mnx (in-k)	Mny (in-k)	Vnx (kip)	End Bearing Pne (kip) Pnei (k/in)	
0.128	0.074	0.000	0.000	3.10	0.00	3.210	0.558	0.491
Torsional Properties								
Xo (in)	Ro (in)	Beta	Cw (in ⁶)	Jv*1000 (in ⁴)	Fy (ksi)	Fu (ksi)	E (ksi)	G (ksi)
-0.743	5.848	0.984	6.12	0.102	50	65	29500	11300

Shear, moment and bearing values shown are nominal values and must be modified by the appropriate factors of safety (ASD) or resistance factors (LRFD).

Factors of Safety (ASD)		Resistance Factors (LRFD)	
Ω (Compression)	= 1.80	ϕ (Compression)	= 0.85
Ω (Tension)	= 1.67	ϕ (Tension)	= 0.95
Ω (Web Crippling)	= 1.85	ϕ (Web Crippling)	= 0.75
Ω (Bending)	= 1.67	ϕ (Bending)	= 1.11
Ω (Shear)	= 1.67	ϕ (Shear)	= 0.90

New Tech 675 Snap-On Panel

Moment of Inertia @ 90 degree Rotation

ELEMENT	L	Y	LY	LYY	I _o
1	0.082	16.383	1.338	21.924	0.0000
2	1.487	16.402	24.390	400.041	0.0000
3	0.195	16.340	3.183	52.005	0.0001
4	0.525	16.278	8.546	139.111	0.0000
5	0.044	16.274	0.716	11.648	0.0000
6	0.349	16.165	5.642	91.195	0.0012
14	15.872	8.414	133.547	1123.664	333.2067
21	0.082	0.445	0.036	0.016	0.0000
22	1.622	0.426	0.691	0.294	0.0000
23	0.082	0.407	0.033	0.014	0.0000
24	0.310	0.219	0.068	0.015	0.0025
25	0.082	0.031	0.003	0.000	0.0000
26	1.060	0.012	0.013	0.000	0.0000
27	0.082	0.031	0.003	0.000	0.0000
28	0.072	0.100	0.007	0.001	0.0000
29	0.109	0.173	0.019	0.003	0.0001
30	0.124	0.150	0.019	0.003	0.0000
	22.177		178.252	1839.934	333.2107

I_x = 17.770 in⁴
 Y_{cg} = 8.038 in

New Tech 675 Snap-On Panel

LOAD

ELEMENT VALUES FOR POSITIVE BENDING					
ELEMENT	L	Y	LY	LYY	Io
1	0.082	0.031	0.003	0.000	0.0000
2	1.487	0.808	1.201	0.970	0.2740
2a	-0.294	1.094	-0.322	-0.352	-0.0021
3	0.195	1.565	0.305	0.477	0.0000
4	0.525	1.288	0.676	0.872	0.0121
5	0.044	1.005	0.044	0.044	0.0000
6	0.280	0.870	0.244	0.212	0.0024
14	15.872	0.012	0.190	0.002	0.0000
21	0.082	0.031	0.003	0.000	0.0000
22	1.622	0.875	1.419	1.242	0.3556
22a	-0.471	1.145	-0.539	-0.617	-0.0087
23	0.082	1.719	0.140	0.241	0.0000
24	0.310	1.738	0.539	0.936	0.0000
25	0.082	1.719	0.140	0.241	0.0000
26	1.060	1.156	1.225	1.417	0.0993
26a	-0.586	1.076	-0.630	-0.678	-0.0168
27	0.082	0.593	0.048	0.029	0.0000
28	0.072	0.574	0.041	0.024	0.0000
29	0.109	0.544	0.059	0.032	0.0000
30	0.124	0.442	0.055	0.024	0.0001
	20.757		4.842	5.116	0.7160

Sx = 0.074 in³
 Ix = 0.113 in⁴
 Ycg = 0.233 in

Webs Fully Effective [SEC. B2.3(a)] | No

New Tech 675 Snap-On Panel

DEFLECTION

ELEMENT VALUES FOR POSITIVE BENDING					
ELEMENT	L	Y	LY	LYY	Io
1	0.082	0.031	0.003	0.000	0.0000
2	1.487	0.808	1.201	0.970	0.2740
3	0.195	1.565	0.305	0.477	0.0000
4	0.525	1.288	0.676	0.872	0.0121
5	0.044	1.005	0.044	0.044	0.0000
6	0.349	0.842	0.294	0.247	0.0024
14	15.872	0.012	0.190	0.002	0.0000
21	0.082	0.031	0.003	0.000	0.0000
22	1.622	0.875	1.419	1.242	0.3556
22a	-0.127	1.218	-0.155	-0.188	-0.0002
23	0.082	1.719	0.140	0.241	0.0000
24	0.310	1.738	0.539	0.936	0.0000
25	0.082	1.719	0.140	0.241	0.0000
26	1.060	1.156	1.225	1.417	0.0993
26a	-0.358	1.121	-0.401	-0.450	-0.0038
27	0.082	0.593	0.048	0.029	0.0000
28	0.072	0.574	0.041	0.024	0.0000
29	0.109	0.544	0.059	0.032	0.0000
30	0.124	0.442	0.055	0.024	0.0001
	21.692		5.827	6.160	0.7396

Sx = 0.086 in³
 Ix = 0.128 in⁴
 Ycg = 0.269 in

Webs Fully Effective [SEC. B2.3(a)] | No

New Tech 675 Snap-On Panel

LOAD

ELEMENT VALUES FOR NEGATIVE BENDING					
ELEMENT	L	Y	LY	LYY	Io
1	0.082	0.031	0.003	0.000	0.0000
2	1.487	0.808	1.201	0.970	0.2740
2a	-0.021	0.327	-0.007	-0.002	-0.0000
3	0.195	1.565	0.305	0.477	0.0000
4	0.525	1.288	0.676	0.872	0.0121
5	0.044	1.005	0.044	0.044	0.0000
6	0.349	0.842	0.294	0.247	0.0024
14	1.144	0.012	0.014	0.000	0.0000
21	0.082	0.031	0.003	0.000	0.0000
22	1.622	0.875	1.419	1.242	0.3556
22a	-0.019	0.320	-0.006	-0.002	-0.0000
23	0.082	1.719	0.140	0.241	0.0000
24	0.310	1.738	0.539	0.936	0.0000
25	0.082	1.719	0.140	0.241	0.0000
26	1.060	1.156	1.225	1.417	0.0993
27	0.082	0.593	0.048	0.029	0.0000
28	0.072	0.574	0.041	0.024	0.0000
29	0.109	0.544	0.059	0.032	0.0000
30	0.124	0.442	0.055	0.024	0.0001
	7.409		6.194	6.792	0.7435

Sx = 0.062 in³
 Ix = 0.057 in⁴
 Ycg = 0.836 in

Webs Fully Effective [SEC. B2.3(a)] | No

New Tech 675 Snap-On Panel

DEFLECTION

ELEMENT VALUES FOR NEGATIVE BENDING

ELEMENT	L	Y	LY	LYY	Io
1	0.082	0.031	0.003	0.000	0.0000
2	1.487	0.808	1.201	0.970	0.2740
3	0.195	1.565	0.305	0.477	0.0000
4	0.525	1.288	0.676	0.872	0.0121
5	0.044	1.005	0.044	0.044	0.0000
6	0.349	0.842	0.294	0.247	0.0024
14	1.542	0.012	0.019	0.000	0.0000
21	0.082	0.031	0.003	0.000	0.0000
22	1.622	0.875	1.419	1.242	0.3556
23	0.082	1.719	0.140	0.241	0.0000
24	0.310	1.738	0.539	0.936	0.0000
25	0.082	1.719	0.140	0.241	0.0000
26	1.060	1.156	1.225	1.417	0.0993
27	0.082	0.593	0.048	0.029	0.0000
28	0.072	0.574	0.041	0.024	0.0000
29	0.109	0.544	0.059	0.032	0.0000
30	0.124	0.442	0.055	0.024	0.0001
	7.847		6.212	6.797	0.7435

Sx = 0.066 in³
 Ix = 0.063 in⁴
 Ycg = 0.792 in

Webs Fully Effective [SEC. B2.3(a)] Yes

New Tech 675 Snap-On Panel

MAXIMUM NOMINAL MOMENTS - [Section C3.1.1(a)]

Mnx [positive bending] = +3.721 k-in
Mnx [negative bending] = -3.096 k-in

MAXIMUM ALLOWABLE REACTIONS - [Table C3.4-1]

N/t = 83.33
k = 1.515
C1 = 0.887
C2 = 0.960
C3 = 0.830
C4 = 0.900
C9 = 1.000
C0 = 1.000 - Element 2, 22
C0 = 1.000 - Element 4
C0 = 1.000 - Element 26

Pend = $t^2 * k * C3 * C4 * C9 * C0 [331 - 0.61(h/t)] [0.71 + 0.015(N/t)]$
h/t = 61.96 | Pe(2) = 1 * 0.375 kips = 0.375 kips
h/t = 21.88 | Pe(4) = 1 * 0.406 kips = 0.406 kips
h/t = 67.58 | Pe(22) = 1 * 0.370 kips = 0.370 kips
h/t = 44.17 | Pe(26) = 1 * 0.389 kips = 0.389 kips
Pend = 1.539 kips

Pint = $t^2 * k * C1 * C2 * C9 * C0 [538 - 0.74(h/t)] [0.75 + 0.011(N/t)]$
h/t = 61.96 | Pi(2) = 1 * 0.609 kips = 0.609 kips
h/t = 21.88 | Pi(4) = 1 * 0.646 kips = 0.646 kips
h/t = 67.58 | Pi(22) = 1 * 0.604 kips = 0.604 kips
h/t = 44.17 | Pi(26) = 1 * 0.626 kips = 0.626 kips
Pint = 2.485 kips

MAXIMUM NOMINAL SHEAR - [Section C3.2]

E = 29,500 ksi
Fy = 50.00 ksi
kv = 5.34 - for unreinforced webs
0.960 * Sqr(Ekv/Fy) = 53.88
1.415 * Sqr(Ekv/Fy) = 79.42

h/t = 61.96 | V(2) = 1 * 1.035 kips = 1.035 kips (Eq. C3.2-2)
h/t = 21.88 | V(4) = 1 * 0.378 kips = 0.378 kips (Eq. C3.2-1)
h/t = 67.58 | V(22) = 1 * 1.035 kips = 1.035 kips (Eq. C3.2-2)
h/t = 44.17 | V(26) = 1 * 0.763 kips = 0.763 kips (Eq. C3.2-1)

Vn = 3.210 kips

New Tech 675 Snap-On Panel

Sheet Gauge = 0.0240 in, 24 gauge

PANEL ELEMENTS EXCEEDING AISI ALLOWABLE RATIOS

Element No. 14 : $w/t > 500$ -Actual $w/t = 661$

NOTE: AISI Specifications, Section B1.1(a) states

stiffened elements having w/t ratios larger than 500 can be used with adequate design strength to sustain the required loads; however; substantial deformations of such elements usually will invalidate the design equations of this Specification.

John F. Butts & Associates, Inc.
2480 Vantage Drive
Colorado Springs, CO 80919
(719) 598-7666

PROFILE ANALYSIS & DESIGN

Per AISI Cold-Formed Steel
Design Manual, 1996 Edition

New Tech 675 Snap-On Panel

=====

FILE NAME: NT675

DIMENSIONS

Line # 1 Angle (R) = -90.000 deg	Line # 1 Angle (L) = 90.000 deg
Radius (R) = 0.040 in	Radius (L) = 0.040 in
Length (R) = 1.487 in	Length (L) = 1.622 in
Line # 2 Angle (R) = 180.000 deg	Line # 2 Angle (L) = -90.000 deg
Radius (R) = 0.050 in	Radius (L) = 0.040 in
Length (R) = 0.525 in	Length (L) = 0.310 in
Line # 3 Angle (R) = 35.000 deg	Line # 3 Angle (L) = -90.000 deg
Radius (R) = 0.060 in	Radius (L) = 0.040 in
Length (R) = 0.349 in	Length (L) = 1.060 in
Line # 4 Angle (R) = 0.000 deg	Line # 4 Angle (L) = -90.000 deg
Radius (R) = 0.000 in	Radius (L) = 0.040 in
Length (R) = 0.000 in	Length (L) = 0.072 in
Line # 5 Angle (R) = 0.000 deg	Line # 5 Angle (L) = 120.000 deg
Radius (R) = 0.000 in	Radius (L) = 0.040 in
Length (R) = 0.000 in	Length (L) = 0.124 in

Panel Bottom Width = 17.872 in
Panel Overall Width = 18.000 in
Panel Overall Height = 1.750 in

Alloy: ASTM A653, G50
Fy = 50.00 ksi
Fv = 25.04 ksi

QUALIFICATIONS PER AISI SPECIFICATIONS

(a) Maximum w/t Ratio's Exceeded [SEC. B1.1(a)] | No
(b) Maximum h/t Ratio's Exceeded [SEC. B1.2(a)] | No

PROPERTIES FOR LOAD/SPAN TABLES

Aweb = 0.128 in ²	Sxp (per ft. of width) = 0.050 in ³
Sxp = 0.074 in ³	Sxn (per ft. of width) = 0.041 in ³
Sxn = 0.062 in ³	Ixp (per ft. of width) = 0.087 in ⁴
Ixp = 0.130 in ⁴	Ixn (per ft. of width) = 0.042 in ⁴
Ixn = 0.063 in ⁴	
Weight = 1.97 lb/lf	

New Tech 675 Snap-On Panel

Member - New Tech 675 Snap-On Panel								
Type	Name	Gage	Hgt (in)	Width (in)	Lip (in)	t (in)	Weight lb/ft	Coil Width (in)
Panel	PNL	24	1.750	18.000	0.000	0.0240	1.974	24.18
Gross Section Properties								
Area (in ²)	Ix (in ⁴)	Sx (in ³)	Rx (in)	Ycg (in)	Iy (in ⁴)	Sy (in ³)	Ry (in)	Xcg (in)
0.580	0.140	0.094	0.492	0.265	23.772	2.536	6.401	9.018
Effective Properties								
Ix (in ⁴)	Sx (in ³)	Iy (in ⁴)	Sy (in ³)	Mnx (in-k)	Mny (in-k)	Vnx (kip)	End Bearing Pne (kip)	Pnei (k/in)
0.130	0.074	0.000	0.000	3.10	0.00	3.210	0.558	0.491
Torsional Properties								
Xc (in)	Ro (in)	Beta	Cw (in ⁶)	Jv*1000 (in ⁴)	Fy (ksi)	Fu (ksi)	E (ksi)	G (ksi)
-0.690	6.456	0.989	7.96	0.111	50	65	29500	11300

Shear, moment and bearing values shown are nominal values and must be modified by the appropriate factors of safety (ASD) or resistance factors (LRFD).

Factors of Safety (ASD)		Resistance Factors (LRFD)	
Ω (Compression)	= 1.80	ϕ (Compression)	= 0.85
Ω (Tension)	= 1.67	ϕ (Tension)	= 0.95
Ω (Web Crippling)	= 1.85	ϕ (Web Crippling)	= 0.75
Ω (Bending)	= 1.67	ϕ (Bending)	= 1.11
Ω (Shear)	= 1.67	ϕ (Shear)	= 0.90

New Tech 675 Snap-On Panel

Moment of Inertia @ 90 degree Rotation

ELEMENT	L	Y	LY	LYY	Io
1	0.082	18.383	1.502	27.603	0.0000
2	1.487	18.402	27.364	503.548	0.0000
3	0.195	18.340	3.572	65.515	0.0001
4	0.525	18.278	9.596	175.395	0.0000
5	0.044	18.274	0.804	14.687	0.0000
6	0.349	18.165	6.340	115.157	0.0012
14	17.872	9.414	168.247	1583.877	475.7055
21	0.082	0.445	0.036	0.016	0.0000
22	1.622	0.426	0.691	0.294	0.0000
23	0.082	0.407	0.033	0.014	0.0000
24	0.310	0.219	0.068	0.015	0.0025
25	0.082	0.031	0.003	0.000	0.0000
26	1.060	0.012	0.013	0.000	0.0000
27	0.082	0.031	0.003	0.000	0.0000
28	0.072	0.100	0.007	0.001	0.0000
29	0.109	0.173	0.019	0.003	0.0001
30	0.124	0.150	0.019	0.003	0.0000
	24.177		218.315	2486.128	475.7095

Ix = 23.772 in⁴
 Ycg = 9.030 in

New Tech 675 Snap-On Panel

LOAD

ELEMENT VALUES FOR POSITIVE BENDING					
ELEMENT	L	Y	LY	LYY	Io
1	0.082	0.031	0.003	0.000	0.0000
2	1.487	0.808	1.201	0.970	0.2740
2a	-0.318	1.080	-0.344	-0.371	-0.0027
3	0.195	1.565	0.305	0.477	0.0000
4	0.525	1.288	0.676	0.872	0.0121
5	0.044	1.005	0.044	0.044	0.0000
6	0.280	0.870	0.244	0.212	0.0024
14	17.872	0.012	0.214	0.003	0.0000
21	0.082	0.031	0.003	0.000	0.0000
22	1.622	0.875	1.419	1.242	0.3556
22a	-0.493	1.132	-0.558	-0.632	-0.0100
23	0.082	1.719	0.140	0.241	0.0000
24	0.310	1.738	0.539	0.936	0.0000
25	0.082	1.719	0.140	0.241	0.0000
26	1.060	1.156	1.225	1.417	0.0993
26a	-0.608	1.063	-0.647	-0.688	-0.0187
27	0.082	0.593	0.048	0.029	0.0000
28	0.072	0.574	0.041	0.024	0.0000
29	0.109	0.544	0.059	0.032	0.0000
30	0.124	0.442	0.055	0.024	0.0001
	22.689		4.809	5.073	0.7122

Sx = 0.074 in³
 Ix = 0.114 in⁴
 Ycg = 0.212 in

Webs Fully Effective [SEC. B2.3(a)] No

New Tech 675 Snap-On Panel

DEFLECTION

ELEMENT VALUES FOR POSITIVE BENDING					
ELEMENT	L	Y	LY	LYY	Io
1	0.082	0.031	0.003	0.000	0.0000
2	1.487	0.808	1.201	0.970	0.2740
3	0.195	1.565	0.305	0.477	0.0000
4	0.525	1.288	0.676	0.872	0.0121
5	0.044	1.005	0.044	0.044	0.0000
6	0.349	0.842	0.294	0.247	0.0024
14	17.872	0.012	0.214	0.003	0.0000
21	0.082	0.031	0.003	0.000	0.0000
22	1.622	0.875	1.419	1.242	0.3556
22a	-0.146	1.205	-0.176	-0.212	-0.0003
23	0.082	1.719	0.140	0.241	0.0000
24	0.310	1.738	0.539	0.936	0.0000
25	0.082	1.719	0.140	0.241	0.0000
26	1.060	1.156	1.225	1.417	0.0993
26a	-0.381	1.108	-0.422	-0.468	-0.0046
27	0.082	0.593	0.048	0.029	0.0000
28	0.072	0.574	0.041	0.024	0.0000
29	0.109	0.544	0.059	0.032	0.0000
30	0.124	0.442	0.055	0.024	0.0001
	23.650		5.809	6.119	0.7387

Sx = 0.087 in³
 Ix = 0.130 in⁴
 Ycg = 0.246 in

Webs Fully Effective [SEC. B2.3(a)] | No

New Tech 675 Snap-On Panel

LOAD

ELEMENT VALUES FOR NEGATIVE BENDING					
ELEMENT	L	Y	LY	LYY	Io
1	0.082	0.031	0.003	0.000	0.0000
2	1.487	0.808	1.201	0.970	0.2740
2a	-0.021	0.327	-0.007	-0.002	-0.0000
3	0.195	1.565	0.305	0.477	0.0000
4	0.525	1.288	0.676	0.872	0.0121
5	0.044	1.005	0.044	0.044	0.0000
6	0.349	0.842	0.294	0.247	0.0024
14	1.146	0.012	0.014	0.000	0.0000
21	0.082	0.031	0.003	0.000	0.0000
22	1.622	0.875	1.419	1.242	0.3556
22a	-0.019	0.320	-0.006	-0.002	-0.0000
23	0.082	1.719	0.140	0.241	0.0000
24	0.310	1.738	0.539	0.936	0.0000
25	0.082	1.719	0.140	0.241	0.0000
26	1.060	1.156	1.225	1.417	0.0993
27	0.082	0.593	0.048	0.029	0.0000
28	0.072	0.574	0.041	0.024	0.0000
29	0.109	0.544	0.059	0.032	0.0000
30	0.124	0.442	0.055	0.024	0.0001
	7.412		6.194	6.792	0.7435

Sx = 0.062 in³
 Ix = 0.057 in⁴
 Ycg = 0.836 in

Webs Fully Effective [SEC. B2.3(a)] | No

New Tech 675 Snap-On Panel

DEFLECTION

ELEMENT VALUES FOR NEGATIVE BENDING

ELEMENT	L	Y	LY	LYY	Io
1	0.082	0.031	0.003	0.000	0.0000
2	1.487	0.808	1.201	0.970	0.2740
3	0.195	1.565	0.305	0.477	0.0000
4	0.525	1.288	0.676	0.872	0.0121
5	0.044	1.005	0.044	0.044	0.0000
6	0.349	0.842	0.294	0.247	0.0024
14	1.546	0.012	0.019	0.000	0.0000
21	0.082	0.031	0.003	0.000	0.0000
22	1.622	0.875	1.419	1.242	0.3556
23	0.082	1.719	0.140	0.241	0.0000
24	0.310	1.738	0.539	0.936	0.0000
25	0.082	1.719	0.140	0.241	0.0000
26	1.060	1.156	1.225	1.417	0.0993
27	0.082	0.593	0.048	0.029	0.0000
28	0.072	0.574	0.041	0.024	0.0000
29	0.109	0.544	0.059	0.032	0.0000
30	0.124	0.442	0.055	0.024	0.0001
	7.851		6.212	6.797	0.7435

Sx = 0.066 in³
 Ix = 0.063 in⁴
 Ycg = 0.791 in

Webs Fully Effective [SEC. B2.3(a)] | Yes

New Tech 675 Snap-On Panel

MAXIMUM NOMINAL MOMENTS - [Section C3.1.1(a)]

Mnx [positive bending] = +3.718 k-in
Mnx [negative bending] = -3.097 k-in

MAXIMUM ALLOWABLE REACTIONS - [Table C3.4-1]

N/t = 83.33
k = 1.515
C1 = 0.887
C2 = 0.960
C3 = 0.830
C4 = 0.900
C9 = 1.000
C0 = 1.000 - Element 2, 22
C0 = 1.000 - Element 4
C0 = 1.000 - Element 26

$$P_{end} = t^2 * k * C3 * C4 * C9 * C0 [331 - 0.61(h/t)] [0.71 + 0.015(N/t)]$$

h/t = 61.96	Pe(2) = 1 * 0.375 kips = 0.375 kips
h/t = 21.88	Pe(4) = 1 * 0.406 kips = 0.406 kips
h/t = 67.58	Pe(22) = 1 * 0.370 kips = 0.370 kips
h/t = 44.17	Pe(26) = 1 * 0.389 kips = 0.389 kips

Pend = 1.539 kips

$$P_{int} = t^2 * k * C1 * C2 * C9 * C0 [538 - 0.74(h/t)] [0.75 + 0.011(N/t)]$$

h/t = 61.96	Pi(2) = 1 * 0.609 kips = 0.609 kips
h/t = 21.88	Pi(4) = 1 * 0.646 kips = 0.646 kips
h/t = 67.58	Pi(22) = 1 * 0.604 kips = 0.604 kips
h/t = 44.17	Pi(26) = 1 * 0.626 kips = 0.626 kips

Pint = 2.485 kips

MAXIMUM NOMINAL SHEAR - [Section C3.2]

E = 29,500 ksi
Fy = 50.00 ksi
kv = 5.34 - for unreinforced webs
0.960 * Sqr(Ekv/Fy) = 53.88
1.415 * Sqr(Ekv/Fy) = 79.42

h/t = 61.96	V(2) = 1 * 1.035 kips = 1.035 kips	(Eq. C3.2-2)
h/t = 21.88	V(4) = 1 * 0.378 kips = 0.378 kips	(Eq. C3.2-1)
h/t = 67.58	V(22) = 1 * 1.035 kips = 1.035 kips	(Eq. C3.2-2)
h/t = 44.17	V(26) = 1 * 0.763 kips = 0.763 kips	(Eq. C3.2-1)

Vn = 3.210 kips

New Tech 675 Snap-On Panel

Sheet Gauge = 0.0240 in, 24 gauge

PANEL ELEMENTS EXCEEDING AISI ALLOWABLE RATIOS

Element No. 14 : $w/t > 500$ -Actual $w/t = 745$

NOTE: AISI Specifications, Section B1.1(a) states

stiffened elements having w/t ratios larger than 500 can be used with adequate design strength to sustain the required loads; however; substantial deformations of such elements usually will invalidate the design equations of this Specification.

New Tech 675 Snap-On Panel

Width		12.00 in								
Alloy		ASTM A653, G50 (Fy= 50 ksi)								
Gauge		24 (0.024 in)								
ALLOWABLE STRENGTH DESIGN (ASD)										
Wind Load Factor = 1.0										
ALLOWABLE UNIFORM LOAD (PSF)										
SPAN	DEFLECTION	SPAN LENGTH (Feet)								
		2.00	2.25	2.50	2.75	3.00	3.25	3.50	3.75	4.00
1	L/180	307	242	196	162	136	115	99	86	76
	L/240	307	242	196	162	136	115	99	86	76
	L/360	307	242	196	162	136	115	99	86	76
2	L/180	307	242	196	162	136	115	99	86	76
	L/240	307	242	196	162	136	115	99	86	76
	L/360	307	242	196	162	136	115	99	86	76
3	L/180	347	275	224	186	156	133	115	100	88
	L/240	347	275	224	186	156	133	115	100	88
	L/360	347	275	224	186	156	133	115	100	88

1. Formula's used in Load Tables for FLEXURE and DEFLECTION are:
 One Span - $M_p = .125wl^2$, $M_n = .125wl^2$, $x = .0130wl^4/EI$
 Two Span - $M_p = .125wl^2$, $M_n = .096wl^2$, $x = .0092wl^4/EI$
 Three Span - $M_p = .080wl^2$, $M_n = .107wl^2$, $x = .0069wl^4/EI$
 Modulus of Elasticity (E) = 29,500 ksi

2. Allowable uniform loads are determined per the following:
 a) Allowable Shear Stress (Fv) [AISI C3.2]
 b) Combined Bending and Shear [AISI C3.3]
 c) Combined Bending & Web Crippling [AISI C3.5]

3. Factors of Safety used to determine uniform loads:
 Ω (Bending) = 1.67
 Ω (Shear) = 1.67
 Ω (Web Crippling) = 1.85

4. Allowance has been made for member Dead Weight.

5. Minimum panel support bearing length = 2.00 in

6. Concentrated load = 150 lb at mid-span, load width = 4 in
 Simple Span : Max. Span = 5.459 ft (L/180)
 Two Span : Max. Span = 6.599 ft (L/180)
 Three Span +: Max. Span = 7.107 ft (L/180)

New Tech 675 Snap-On Panel

Width	12.00 in
Alloy	ASTM A653, G50 (Fy= 50 ksi)
Gauge	24 (0.024 in)

ALLOWABLE STRENGTH DESIGN (ASD)
Wind Load Factor = 1.0
ALLOWABLE UNIFORM LOAD (PSF)

SPAN	DEFLECTION	SPAN LENGTH (Feet)								
		4.25	4.50	4.75	5.00	5.25	5.50	5.75	6.00	6.25
1	L/180	67	59	53	48	43	39	36	33	30
	L/240	67	59	53	48	43	39	36	33	30
	L/360	67	57	49	42	36	31	27	24	21
2	L/180	67	59	53	48	43	39	36	33	30
	L/240	67	59	53	48	43	39	36	33	30
	L/360	67	59	53	48	43	39	36	33	30
3	L/180	78	69	62	56	51	46	42	38	35
	L/240	78	69	62	56	51	46	42	38	35
	L/360	78	69	62	56	51	46	42	38	35

- Formula's used in Load Tables for FLEXURE and DEFLECTION are:
 One Span - $M_p = .125wl^2$, $M_n = .125wl^2$, $x = .0130wl^4/EI$
 Two Span - $M_p = .125wl^2$, $M_n = .096wl^2$, $x = .0092wl^4/EI$
 Three Span - $M_p = .080wl^2$, $M_n = .107wl^2$, $x = .0069wl^4/EI$
 Modulus of Elasticity (E) = 29,500 ksi
- Allowable uniform loads are determined per the following:
 - Allowable Shear Stress (Fv) [AISI C3.2]
 - Combined Bending and Shear [AISI C3.3]
 - Combined Bending & Web Crippling [AISI C3.5]
- Factors of Safety used to determine uniform loads:
 - Ω (Bending) = 1.67
 - Ω (Shear) = 1.67
 - Ω (Web Crippling) = 1.85
- Allowance has been made for member Dead Weight.
- Minimum panel support bearing length = 2.00 in
- Concentrated load = 150 lb at mid-span, load width = 4 in
 - Simple Span : Max. Span = 5.459 ft (L/180)
 - Two Span : Max. Span = 6.599 ft (L/180)
 - Three Span +: Max. Span = 7.107 ft (L/180)

New Tech 675 Snap-On Panel

Width		12.00 in								
Alloy		ASTM A653, G50 (Fy= 50 ksi)								
Gauge		24 (0.024 in)								
ALLOWABLE STRENGTH DESIGN (ASD)										
Wind Load Factor = 1.0										
ALLOWABLE UNIFORM LOAD (PSF)										
SPAN	DEFLECTION	SPAN LENGTH (Feet)								
		6.50	6.75	7.00	7.25	7.50	7.75	8.00	8.25	8.50
1	L/180	28	26	24	22	20	19	18	17	16
	L/240	28	25	23	21	19	17	15	14	13
	L/360	19	17	15	14	12	11	10	9	8
2	L/180	28	26	24	22	20	19	18	17	16
	L/240	28	26	24	22	20	19	18	17	16
	L/360	27	24	22	19	17	16	14	13	12
3	L/180	32	30	28	26	24	22	21	20	18
	L/240	32	30	28	26	24	22	21	20	18
	L/360	32	30	28	26	23	21	19	18	16

1. Formula's used in Load Tables for FLEXURE and DEFLECTION are:

One Span - $M_p = .125wl^2$, $M_n = .125wl^2$, $x = .0130wl^4/EI$
 Two Span - $M_p = .125wl^2$, $M_n = .096wl^2$, $x = .0092wl^4/EI$
 Three Span - $M_p = .080wl^2$, $M_n = .107wl^2$, $x = .0069wl^4/EI$
 Modulus of Elasticity (E) = 29,500 ksi

2. Allowable uniform loads are determined per the following:

- a) Allowable Shear Stress (Fv) [AISI C3.2]
- b) Combined Bending and Shear [AISI C3.3]
- c) Combined Bending & Web Crippling [AISI C3.5]

3. Factors of Safety used to determine uniform loads:

Ω (Bending) = 1.67
 Ω (Shear) = 1.67
 Ω (Web Crippling) = 1.85

4. Allowance has been made for member Dead Weight.

5. Minimum panel support bearing length = 2.00 in

6. Concentrated load = 150 lb at mid-span, load width = 4 in

Simple Span : Max. Span = 5.459 ft (L/180)
 Two Span : Max. Span = 6.599 ft (L/180)
 Three Span +: Max. Span = 7.107 ft (L/180)

New Tech 675 Snap-On Panel

Width	12.00 in
Alloy	ASTM A653, G50 (Fy= 50 ksi)
Gauge	24 (0.024 in)

ALLOWABLE STRENGTH DESIGN (ASD)
Wind Load Factor = 1.0
ALLOWABLE UNIFORM LOAD (PSF)

SPAN	DEFLECTION	SPAN LENGTH (Feet)								
		8.50	8.75	9.00	9.25	9.50	9.75	10.00	10.25	10.50
1	L/180	16	15	14	13	12	11	10	10	9
	L/240	13	12	11	10	9	8	8	7	7
	L/360	8	8	7	7	6	6	5	5	5
2	L/180	16	15	14	13	12	11	11	10	10
	L/240	16	15	14	13	12	11	11	10	10
	L/360	12	11	10	9	9	8	7	7	6
3	L/180	18	17	16	15	14	14	13	12	12
	L/240	18	17	16	15	14	14	13	12	12
	L/360	16	15	13	12	11	11	10	9	8

- Formula's used in Load Tables for FLEXURE and DEFLECTION are:
 One Span - $M_p = .125wl^2$, $M_n = .125wl^2$, $x = .0130wl^4/EI$
 Two Span - $M_p = .125wl^2$, $M_n = .096wl^2$, $x = .0092wl^4/EI$
 Three Span - $M_p = .080wl^2$, $M_n = .107wl^2$, $x = .0069wl^4/EI$
 Modulus of Elasticity (E) = 29,500 ksi

- Allowable uniform loads are determined per the following:
 - Allowable Shear Stress (Fv) [AISI C3.2]
 - Combined Bending and Shear [AISI C3.3]
 - Combined Bending & Web Crippling [AISI C3.5]

- Factors of Safety used to determine uniform loads:
 - Ω (Bending) = 1.67
 - Ω (Shear) = 1.67
 - Ω (Web Crippling) = 1.85

4. Allowance has been made for member Dead Weight.

5. Minimum panel support bearing length = 2.00 in

- Concentrated load = 150 lb at mid-span, load width = 4 in
 - Simple Span : Max. Span = 5.459 ft (L/180)
 - Two Span : Max. Span = 6.599 ft (L/180)
 - Three Span +: Max. Span = 7.107 ft (L/180)

New Tech 675 Snap-On Panel

Width	14.00 in
Alloy	ASTM A653, G50 (Fy= 50 ksi)
Gauge	24 (0.024 in)

ALLOWABLE STRENGTH DESIGN (ASD)
Wind Load Factor = 1.0
ALLOWABLE UNIFORM LOAD (PSF)
SPAN LENGTH (Feet)

SPAN	DEFLECTION	ALLOWABLE UNIFORM LOAD (PSF)								
		2.00	2.25	2.50	2.75	3.00	3.25	3.50	3.75	4.00
1	L/180	263	208	168	139	116	99	85	74	65
	L/240	263	208	168	139	116	99	85	74	65
	L/360	263	208	168	139	116	99	85	74	65
2	L/180	263	208	168	139	116	99	85	74	65
	L/240	263	208	168	139	116	99	85	74	65
	L/360	263	208	168	139	116	99	85	74	65
3	L/180	297	236	192	159	134	114	98	86	75
	L/240	297	236	192	159	134	114	98	86	75
	L/360	297	236	192	159	134	114	98	86	75

- Formula's used in Load Tables for FLEXURE and DEFLECTION are:
 One Span - $M_p = .125wl^2$, $M_n = .125wl^2$, $x = .0130wl^4/EI$
 Two Span - $M_p = .125wl^2$, $M_n = .096wl^2$, $x = .0092wl^4/EI$
 Three Span - $M_p = .080wl^2$, $M_n = .107wl^2$, $x = .0069wl^4/EI$
 Modulus of Elasticity (E) = 29,500 ksi

- Allowable uniform loads are determined per the following:
 - Allowable Shear Stress (Fv) [AISI C3.2]
 - Combined Bending and Shear [AISI C3.3]
 - Combined Bending & Web Crippling [AISI C3.5]

- Factors of Safety used to determine uniform loads:
 - Ω (Bending) = 1.67
 - Ω (Shear) = 1.67
 - Ω (Web Crippling) = 1.85

4. Allowance has been made for member Dead Weight.

5. Minimum panel support bearing length = 2.00 in

- Concentrated load = 150 lb at mid-span, load width = 4 in
 - Simple Span : Max. Span = 5.455 ft (L/180)
 - Two Span : Max. Span = 6.594 ft (L/180)
 - Three Span : Max. Span = 7.102 ft (L/180)

New Tech 675 Snap-On Panel

Width	14.00 in
Alloy	ASTM A653, G50 (Fy= 50 ksi)
Gauge	24 (0.024 in)

ALLOWABLE STRENGTH DESIGN (ASD)

Wind Load Factor = 1.0

ALLOWABLE UNIFORM LOAD (PSF)

SPAN	DEFLECTION	SPAN LENGTH (Feet)								
		4.25	4.50	4.75	5.00	5.25	5.50	5.75	6.00	6.25
1	L/180	57	51	46	41	37	34	31	28	26
	L/240	57	51	46	41	37	34	31	28	26
	L/360	57	51	44	38	32	28	25	22	19
2	L/180	57	51	46	41	37	34	31	28	26
	L/240	57	51	46	41	37	34	31	28	26
	L/360	57	51	46	41	37	34	31	28	26
3	L/180	66	59	53	48	43	39	36	33	30
	L/240	66	59	53	48	43	39	36	33	30
	L/360	66	59	53	48	43	39	36	33	30

1. Formula's used in Load Tables for FLEXURE and DEFLECTION are:

One Span - $M_p = .125wl^2$, $M_n = .125wl^2$, $x = .0130wl^4/EI$

Two Span - $M_p = .125wl^2$, $M_n = .096wl^2$, $x = .0092wl^4/EI$

Three Span - $M_p = .080wl^2$, $M_n = .107wl^2$, $x = .0069wl^4/EI$

Modulus of Elasticity (E) = 29,500 ksi

2. Allowable uniform loads are determined per the following:

a) Allowable Shear Stress (Fv) [AISI C3.2]

b) Combined Bending and Shear [AISI C3.3]

c) Combined Bending & Web Crippling [AISI C3.5]

3. Factors of Safety used to determine uniform loads:

Ω (Bending) = 1.67

Ω (Shear) = 1.67

Ω (Web Crippling) = 1.85

4. Allowance has been made for member Dead Weight.

5. Minimum panel support bearing length = 2.00 in

6. Concentrated load = 150 lb at mid-span, load width = 4 in

Simple Span : Max. Span = 5.455 ft (L/180)

Two Span : Max. Span = 6.594 ft (L/180)

Three Span +: Max. Span = 7.102 ft (L/180)

New Tech 675 Snap-On Panel

Width		14.00 in								
Alloy		ASTM A653, G50 (Fy= 50 ksi)								
Gauge		24 (0.024 in)								
ALLOWABLE STRENGTH DESIGN (ASD)										
Wind Load Factor = 1.0										
ALLOWABLE UNIFORM LOAD (PSF)										
SPAN	DEFLECTION	SPAN LENGTH (Feet)								
		6.50	6.75	7.00	7.25	7.50	7.75	8.00	8.25	8.50
1	L/180	24	22	20	19	17	16	15	14	13
	L/240	24	22	20	18	17	15	14	13	11
	L/360	17	15	14	12	11	10	9	8	8
2	L/180	24	22	20	19	17	16	15	14	13
	L/240	24	22	20	19	17	16	15	14	13
	L/360	24	22	19	17	16	14	13	12	11
3	L/180	28	26	24	22	20	19	18	17	16
	L/240	28	26	24	22	20	19	18	17	16
	L/360	28	26	24	22	20	19	17	16	14

- Formula's used in Load Tables for FLEXURE and DEFLECTION are:
 One Span - $M_p = .125wl^2$, $M_n = .125wl^2$, $x = .0130wl^4/EI$
 Two Span - $M_p = .125wl^2$, $M_n = .096wl^2$, $x = .0092wl^4/EI$
 Three Span - $M_p = .080wl^2$, $M_n = .107wl^2$, $x = .0069wl^4/EI$
 Modulus of Elasticity (E) = 29,500 ksi
- Allowable uniform loads are determined per the following:
 - Allowable Shear Stress (Fv) [AISI C3.2]
 - Combined Bending and Shear [AISI C3.3]
 - Combined Bending & Web Crippling [AISI C3.5]
- Factors of Safety used to determine uniform loads:
 - Ω (Bending) = 1.67
 - Ω (Shear) = 1.67
 - Ω (Web Crippling) = 1.85
- Allowance has been made for member Dead Weight.
- Minimum panel support bearing length = 2.00 in
- Concentrated load = 150 lb at mid-span, load width = 4 in
 - Simple Span : Max. Span = 5.455 ft (L/180)
 - Two Span : Max. Span = 6.594 ft (L/180)
 - Three Span +: Max. Span = 7.102 ft (L/180)

New Tech 675 Snap-On Panel

Width	14.00 in
Alloy	ASTM A653, G50 (Fy= 50 ksi)
Gauge	24 (0.024 in)

ALLOWABLE STRENGTH DESIGN (ASD)
Wind Load Factor = 1.0
ALLOWABLE UNIFORM LOAD (PSF)
SPAN LENGTH (Feet)

SPAN	DEFLECTION	8.75	9.00	9.25	9.50	9.75	10.00	10.25	10.50	10.75
1	L/180	12	12	11	10	10	9	9	8	8
	L/240	11	10	9	8	8	7	7	6	6
	L/360	7	6	6	5	5	5	4	4	4
2	L/180	12	12	11	10	10	9	9	8	8
	L/240	12	12	11	10	10	9	9	8	8
	L/360	10	9	8	8	7	7	6	6	5
3	L/180	15	14	13	12	12	11	10	10	9
	L/240	15	14	13	12	12	11	10	10	9
	L/360	13	12	11	10	10	9	8	8	7

- Formula's used in Load Tables for FLEXURE and DEFLECTION are:
 One Span - $M_p = .125wl^2$, $M_n = .125wl^2$, $x = .0130wl^4/EI$
 Two Span - $M_p = .125wl^2$, $M_n = .096wl^2$, $x = .0092wl^4/EI$
 Three Span - $M_p = .080wl^2$, $M_n = .107wl^2$, $x = .0069wl^4/EI$
 Modulus of Elasticity (E) = 29,500 ksi

- Allowable uniform loads are determined per the following:
 - Allowable Shear Stress (Fv) [AISI C3.2]
 - Combined Bending and Shear [AISI C3.3]
 - Combined Bending & Web Crippling [AISI C3.5]

- Factors of Safety used to determine uniform loads:
 - Ω (Bending) = 1.67
 - Ω (Shear) = 1.67
 - Ω (Web Crippling) = 1.85

4. Allowance has been made for member Dead Weight.

5. Minimum panel support bearing length = 2.00 in

- Concentrated load = 150 lb at mid-span, load width = 4 in
 - Simple Span : Max. Span = 5.455 ft (L/180)
 - Two Span : Max. Span = 6.594 ft (L/180)
 - Three Span +: Max. Span = 7.102 ft (L/180)

New Tech 675 Snap-On Panel

Width	16.00 in
Alloy	ASTM A653, G50 (Fy= 50 ksi)
Gauge	24 (0.024 in)

ALLOWABLE STRENGTH DESIGN (ASD)
Wind Load Factor = 1.0
ALLOWABLE UNIFORM LOAD (PSF)
SPAN LENGTH (Feet)

SPAN	DEFLECTION	SPAN LENGTH (Feet)								
		2.00	2.25	2.50	2.75	3.00	3.25	3.50	3.75	4.00
1	L/180	230	182	147	121	102	86	74	65	57
	L/240	230	182	147	121	102	86	74	65	57
	L/360	230	182	147	121	102	86	74	65	57
2	L/180	230	182	147	121	102	86	74	65	57
	L/240	230	182	147	121	102	86	74	65	57
	L/360	230	182	147	121	102	86	74	65	57
3	L/180	260	207	168	139	117	100	86	75	66
	L/240	260	207	168	139	117	100	86	75	66
	L/360	260	207	168	139	117	100	86	75	66

- Formula's used in Load Tables for FLEXURE and DEFLECTION are:
 One Span - $M_p = .125wl^2$, $M_n = .125wl^2$, $x = .0130wl^4/EI$
 Two Span - $M_p = .125wl^2$, $M_n = .096wl^2$, $x = .0092wl^4/EI$
 Three Span - $M_p = .080wl^2$, $M_n = .107wl^2$, $x = .0069wl^4/EI$
 Modulus of Elasticity (E) = 29,500 ksi

- Allowable uniform loads are determined per the following:
 - Allowable Shear Stress (Fv) [AISI C3.2]
 - Combined Bending and Shear [AISI C3.3]
 - Combined Bending & Web Crippling [AISI C3.5]

- Factors of Safety used to determine uniform loads:
 - Ω (Bending) = 1.67
 - Ω (Shear) = 1.67
 - Ω (Web Crippling) = 1.85

4. Allowance has been made for member Dead Weight.

5. Minimum panel support bearing length = 2.00 in

- Concentrated load = 150 lb at mid-span, load width = 4 in
 - Simple Span : Max. Span = 5.451 ft (L/180)
 - Two Span : Max. Span = 6.590 ft (L/180)
 - Three Span : Max. Span = 7.097 ft (L/180)

New Tech 675 Snap-On Panel

Width		16.00 in								
Alloy		ASTM A653, G50 (Fy= 50 ksi)								
Gauge		24 (0.024 in)								
ALLOWABLE STRENGTH DESIGN (ASD)										
Wind Load Factor = 1.0										
ALLOWABLE UNIFORM LOAD (PSF)										
SPAN	DEFLECTION	SPAN LENGTH (Feet)								
		4.25	4.50	4.75	5.00	5.25	5.50	5.75	6.00	6.25
1	L/180	50	44	40	36	32	29	27	24	22
	L/240	50	44	40	36	32	29	27	24	22
	L/360	50	44	39	34	29	25	22	19	17
2	L/180	50	44	40	36	32	29	27	24	22
	L/240	50	44	40	36	32	29	27	24	22
	L/360	50	44	40	36	32	29	27	24	22
3	L/180	58	52	46	42	38	34	31	29	26
	L/240	58	52	46	42	38	34	31	29	26
	L/360	58	52	46	42	38	34	31	29	26

- Formula's used in Load Tables for FLEXURE and DEFLECTION are:
 One Span - $M_p = .125wl^2$, $M_n = .125wl^2$, $x = .0130wl^4/EI$
 Two Span - $M_p = .125wl^2$, $M_n = .096wl^2$, $x = .0092wl^4/EI$
 Three Span - $M_p = .080wl^2$, $M_n = .107wl^2$, $x = .0069wl^4/EI$
 Modulus of Elasticity (E) = 29,500 ksi
- Allowable uniform loads are determined per the following:
 - Allowable Shear Stress (Fv) [AISI C3.2]
 - Combined Bending and Shear [AISI C3.3]
 - Combined Bending & Web Crippling [AISI C3.5]
- Factors of Safety used to determine uniform loads:
 - Ω (Bending) = 1.67
 - Ω (Shear) = 1.67
 - Ω (Web Crippling) = 1.85
- Allowance has been made for member Dead Weight.
- Minimum panel support bearing length = 2.00 in
- Concentrated load = 150 lb at mid-span, load width = 4 in
 - Simple Span : Max. Span = 5.451 ft (L/180)
 - Two Span : Max. Span = 6.590 ft (L/180)
 - Three Span +: Max. Span = 7.097 ft (L/180)

New Tech 675 Snap-On Panel

Width | 16.00 in
Alloy | ASTM A653, G50 (Fy= 50 ksi)
Gauge | 24 (0.024 in)

ALLOWABLE STRENGTH DESIGN (ASD)
Wind Load Factor = 1.0
ALLOWABLE UNIFORM LOAD (PSF)
SPAN LENGTH (Feet)

SPAN DEFLECTION		SPAN LENGTH (Feet)								
		6.50	6.75	7.00	7.25	7.50	7.75	8.00	8.25	8.50
1	L/180	21	19	18	16	15	14	13	12	11
	L/240	21	19	18	16	15	14	12	11	10
	L/360	15	14	12	11	10	9	8	7	7
2	L/180	21	19	18	16	15	14	13	12	11
	L/240	21	19	18	16	15	14	13	12	11
	L/360	21	19	17	16	14	13	12	11	10
3	L/180	24	22	21	19	18	17	16	15	14
	L/240	24	22	21	19	18	17	16	15	14
	L/360	24	22	21	19	18	17	15	14	13

- Formula's used in Load Tables for FLEXURE and DEFLECTION are:
 One Span - $M_p = .125wl^2$, $M_n = .125wl^2$, $x = .0130wl^4/EI$
 Two Span - $M_p = .125wl^2$, $M_n = .096wl^2$, $x = .0092wl^4/EI$
 Three Span - $M_p = .080wl^2$, $M_n = .107wl^2$, $x = .0069wl^4/EI$
 Modulus of Elasticity (E) = 29,500 ksi
- Allowable uniform loads are determined per the following:
 - Allowable Shear Stress (Fv) [AISI C3.2]
 - Combined Bending and Shear [AISI C3.3]
 - Combined Bending & Web Crippling [AISI C3.5]
- Factors of Safety used to determine uniform loads:
 - Ω (Bending) = 1.67
 - Ω (Shear) = 1.67
 - Ω (Web Crippling) = 1.85
- Allowance has been made for member Dead Weight.
- Minimum panel support bearing length = 2.00 in
- Concentrated load = 150 lb at mid-span, load width = 4 in
 - Simple Span : Max. Span = 5.451 ft (L/180)
 - Two Span : Max. Span = 6.590 ft (L/180)
 - Three Span +: Max. Span = 7.097 ft (L/180)

New Tech 675 Snap-On Panel

=====										
Width	16.00 in									
Alloy	ASTM A653, G50 (Fy= 50 ksi)									
Gauge	24 (0.024 in)									
=====										
ALLOWABLE STRENGTH DESIGN (ASD)										
Wind Load Factor = 1.0										
ALLOWABLE UNIFORM LOAD (PSF)										
SPAN	DEFLECTION	SPAN LENGTH (Feet)								
		8.75	9.00	9.25	9.50	9.75	10.00	10.25	10.50	10.75
1	L/180	11	10	9	9	8	8	7	7	7
	L/240	9	9	8	7	7	6	6	5	5
	L/360	6	6	5	5	5	4	4	4	3
2	L/180	11	10	9	9	8	8	7	7	7
	L/240	11	10	9	9	8	8	7	7	7
	L/360	9	8	8	7	6	6	6	5	5
3	L/180	13	12	11	11	10	9	9	8	8
	L/240	13	12	11	11	10	9	9	8	8
	L/360	12	11	10	9	9	8	7	7	6

- Formula's used in Load Tables for FLEXURE and DEFLECTION are:
 One Span - $M_p = .125wl^2$, $M_n = .125wl^2$, $x = .0130wl^4/EI$
 Two Span - $M_p = .125wl^2$, $M_n = .096wl^2$, $x = .0092wl^4/EI$
 Three Span - $M_p = .080wl^2$, $M_n = .107wl^2$, $x = .0069wl^4/EI$
 Modulus of Elasticity (E) = 29,500 ksi
- Allowable uniform loads are determined per the following:
 - Allowable Shear Stress (Fv) [AISI C3.2]
 - Combined Bending and Shear [AISI C3.3]
 - Combined Bending & Web Crippling [AISI C3.5]
- Factors of Safety used to determine uniform loads:
 - Ω (Bending) = 1.67
 - Ω (Shear) = 1.67
 - Ω (Web Crippling) = 1.85
- Allowance has been made for member Dead Weight.
- Minimum panel support bearing length = 2.00 in
- Concentrated load = 150 lb at mid-span, load width = 4 in
 - Simple Span : Max. Span = 5.451 ft (L/180)
 - Two Span : Max. Span = 6.590 ft (L/180)
 - Three Span +: Max. Span = 7.097 ft (L/180)

New Tech 675 Snap-On Panel

		=====								
Width	18.00 in									
Alloy	ASTM A653, G50 (Fy= 50 ksi)									
Gauge	24 (0.024 in)									
		=====								
		ALLOWABLE STRENGTH DESIGN (ASD)								
		Wind Load Factor = 1.0								
		ALLOWABLE UNIFORM LOAD (PSF)								
SPAN	DEFLECTION	SPAN LENGTH (Feet)								
		2.00	2.25	2.50	2.75	3.00	3.25	3.50	3.75	4.00
1	L/180	205	161	131	108	90	77	66	57	50
	L/240	205	161	131	108	90	77	66	57	50
	L/360	205	161	131	108	90	77	66	57	50
2	L/180	205	161	131	108	90	77	66	57	50
	L/240	205	161	131	108	90	77	66	57	50
	L/360	205	161	131	108	90	77	66	57	50
3	L/180	231	184	149	124	104	89	76	66	58
	L/240	231	184	149	124	104	89	76	66	58
	L/360	231	184	149	124	104	89	76	66	58

- Formula's used in Load Tables for FLEXURE and DEFLECTION are:
 One Span - $M_p = .125wl^2$, $M_n = .125wl^2$, $x = .0130wl^4/EI$
 Two Span - $M_p = .125wl^2$, $M_n = .096wl^2$, $x = .0092wl^4/EI$
 Three Span - $M_p = .080wl^2$, $M_n = .107wl^2$, $x = .0069wl^4/EI$
 Modulus of Elasticity (E) = 29,500 ksi
- Allowable uniform loads are determined per the following:
 - Allowable Shear Stress (Fv) [AISI C3.2]
 - Combined Bending and Shear [AISI C3.3]
 - Combined Bending & Web Crippling [AISI C3.5]
- Factors of Safety used to determine uniform loads:
 - Ω (Bending) = 1.67
 - Ω (Shear) = 1.67
 - Ω (Web Crippling) = 1.85
- Allowance has been made for member Dead Weight.
- Minimum panel support bearing length = 2.00 in
- Concentrated load = 150 lb at mid-span, load width = 4 in
 - Simple Span : Max. Span = 5.448 ft (L/180)
 - Two Span : Max. Span = 6.586 ft (L/180)
 - Three Span +: Max. Span = 6.793 ft (L/180)

New Tech 675 Snap-On Panel

Width		18.00 in								
Alloy		ASTM A653, G50 (Fy= 50 ksi)								
Gauge		24 (0.024 in)								
ALLOWABLE STRENGTH DESIGN (ASD)										
Wind Load Factor = 1.0										
ALLOWABLE UNIFORM LOAD (PSF)										
SPAN	DEFLECTION	SPAN LENGTH (Feet)								
		4.25	4.50	4.75	5.00	5.25	5.50	5.75	6.00	6.25
1	L/180	44	39	35	32	29	26	24	22	20
	L/240	44	39	35	32	29	26	24	22	20
	L/360	44	39	35	30	26	23	20	18	16
2	L/180	44	39	35	32	29	26	24	22	20
	L/240	44	39	35	32	29	26	24	22	20
	L/360	44	39	35	32	29	26	24	22	20
3	L/180	52	46	41	37	33	30	28	25	23
	L/240	52	46	41	37	33	30	28	25	23
	L/360	52	46	41	37	33	30	28	25	23

1. Formula's used in Load Tables for FLEXURE and DEFLECTION are:

One Span - $M_p = .125wl^2$, $M_n = .125wl^2$, $x = .0130wl^4/EI$
 Two Span - $M_p = .125wl^2$, $M_n = .096wl^2$, $x = .0092wl^4/EI$
 Three Span - $M_p = .080wl^2$, $M_n = .107wl^2$, $x = .0069wl^4/EI$
 Modulus of Elasticity (E) = 29,500 ksi

2. Allowable uniform loads are determined per the following:

- a) Allowable Shear Stress (Fv) [AISI C3.2]
- b) Combined Bending and Shear [AISI C3.3]
- c) Combined Bending & Web Crippling [AISI C3.5]

3. Factors of Safety used to determine uniform loads:

Ω (Bending) = 1.67
 Ω (Shear) = 1.67
 Ω (Web Crippling) = 1.85

4. Allowance has been made for member Dead Weight.

5. Minimum panel support bearing length = 2.00 in

6. Concentrated load = 150 lb at mid-span, load width = 4 in

Simple Span : Max. Span = 5.448 ft (L/180)
 Two Span : Max. Span = 6.586 ft (L/180)
 Three Span +: Max. Span = 6.793 ft (L/180)

New Tech 675 Snap-On Panel

		ALLOWABLE STRENGTH DESIGN (ASD)								
		Wind Load Factor = 1.0								
		ALLOWABLE UNIFORM LOAD (PSF)								
SPAN	DEFLECTION	SPAN LENGTH (Feet)								
		6.75	7.00	7.25	7.50	7.75	8.00	8.25	8.50	8.75
1	L/180	17	16	14	13	12	12	11	10	9
	L/240	17	16	14	13	12	11	10	9	9
	L/360	12	11	10	9	8	7	7	6	6
2	L/180	17	16	14	13	12	12	11	10	9
	L/240	17	16	14	13	12	12	11	10	9
	L/360	17	16	14	13	12	10	10	9	8
3	L/180	20	18	17	16	15	14	13	12	11
	L/240	20	18	17	16	15	14	13	12	11
	L/360	20	18	17	16	15	14	13	12	11

1. Formula's used in Load Tables for FLEXURE and DEFLECTION are:

- One Span - $M_p = .125wl^2$, $M_n = .125wl^2$, $x = .0130wl^4/EI$
- Two Span - $M_p = .125wl^2$, $M_n = .096wl^2$, $x = .0092wl^4/EI$
- Three Span - $M_p = .080wl^2$, $M_n = .107wl^2$, $x = .0069wl^4/EI$
- Modulus of Elasticity (E) = 29,500 ksi

2. Allowable uniform loads are determined per the following:

- a) Allowable Shear Stress (Fv) [AISI C3.2]
- b) Combined Bending and Shear [AISI C3.3]
- c) Combined Bending & Web Crippling [AISI C3.5]

3. Factors of Safety used to determine uniform loads:

- Ω (Bending) = 1.67
- Ω (Shear) = 1.67
- Ω (Web Crippling) = 1.85

4. Allowance has been made for member Dead Weight.

5. Minimum panel support bearing length = 2.00 in

6. Concentrated load = 150 lb at mid-span, load width = 4 in

- Simple Span : Max. Span = 5.448 ft (L/180)
- Two Span : Max. Span = 6.586 ft (L/180)
- Three Span +: Max. Span = 6.793 ft (L/180)